

Nature is an extraordinary master in the art of creating lights and shadows. It offers scenarios that tell of contrasts and balances, it shows how lights and shadows are inseparable from each other: one, without the other. Just as, without the sun, we would not be able to see the moon. Two sides of the same coin: complementary and in perfect harmony.



Divani / Sofas	06-31	Match_
	34 - 43	Swing_
	46 - 55	Percy_
	58 - 71	Panuma
	74 - 83	Geo_
	84 - 93	Globo_
	96 - 103	Bon Bon_
	104 - 109	Bon Bon Up_
	112 - 129	Sospiro_
	132 - 141	Nuvola_
	144 - 153	Chicca
	156 - 165	Sipario_
	168 - 177	Morfeo_
	180 - 197	Modula_

Poltrone / Armchairs	200 - 205	Dana_
	206 - 211	Muzzle_
	212 - 217	Abbracci_
	218 - 223	Swing_
	224 - 229	Ember_
	230 - 235	Scott_
	236 - 241	Perla_

Tavolini e Pouff / Accessories	242 - 247	Krisa_
	248 - 253	Tarkin_
	254 - 259	Manfi_
	260 - 265	Kea_
	266 - 271	Muzzle_
	272 - 277	Leia_

Schede Tecniche / Technical sheet	280 - 300
Cuscini / Pillows	301

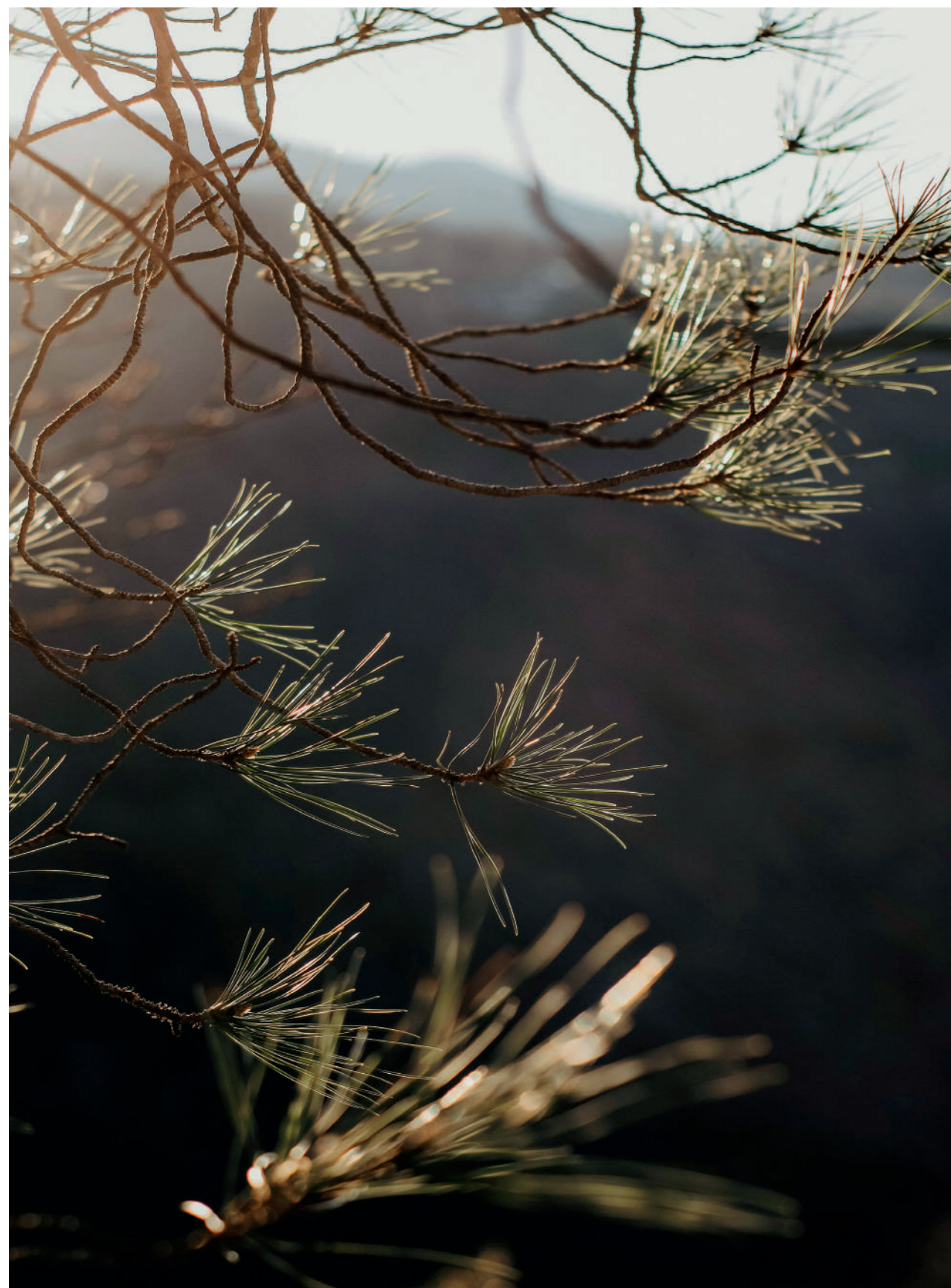

the colors of the soul belong to nature

## Match\_

Il divano modulare Match offre molteplici combinazioni di elementi e rivestimenti. Design, comfort e cura dei dettagli lo rendono il protagonista assoluto del tuo living, garantendo uno stile unico e personalizzato.

Match is a modular sofa that offers multiple combinations of items and covers. Design, comfort and care to details make the Match the star attraction in your living room with a unique and customized style.





mod. Match  
v. 802 - 1013 - 621 - 7501  
7501 - 7249 - 113 - 621

mod. Manfi - coffee tables  
v.1704 - 1701 - 1704 - 1515

Match\_





Match\_



*mod. Match*  
v. 114 - 621 - 7501 - 7125 - 621  
*mod. Manfi - coffee table*  
v. 1701



*mod. Match*  
v. 114 - 621 - 7125 - 621 - 7501



Match\_





mod. Match  
v. 7249 - 621 - 7501 - 1013 - 621  
113 - 621 - 7501 - 802 - 621

mod. Manfi - coffee tables  
v. 1704 - 1701 - 1515

Match\_





mod. Match  
v. 802 - 621 - 113 - 621

mod. Manfi - coffee tables  
v.1704 - 1515 - 1707 - 1701

Match\_





mod. Match  
v. 1014 - 621 - 245 - 621

mod. Kisa - coffee tables  
v.1515 - 1502 - 1707

mod. Swing - armchairs  
v. 111 - 125

mod. Kisa - coffee tables  
v. 1707

Match\_





*mod. Match*  
v. 1014 - 621 - 245 - 621

*mod. Swing - armchair*  
v. 111

*mod. Krisa - coffee tables*  
v. 1515 - 1502 - 1707



nature paints for us and is a source of inspiration

## Swing\_

Divano modulare con funzioni di dondolo e girevole. Unisce comfort e design ricercato, dove ogni dettaglio diventa protagonista per offrire un'esperienza di relax unica e sofisticata.

Modular sofa with rocking and swivel systems. A combination of comfort and refined design, where details play a leading role to offer a unique and sophisticated relaxation experience.





mod. Swing  
v. 111 - 111 - 501 - 125 - 113 - 501  
mod. Kisa - coffee tables  
v. 1707 - 1515 - 1502

Swing\_





Swing\_



*mod. Swing*  
v. 501 - 125 125





nature in the contrast of colors

## Percy\_

Dinamico e lineare, Percy ha un'anima elegante e una forte personalità. Le linee geometriche sono bilanciate dalla morbidezza degli imbottiti della seduta, trapuntata con un originale motivo asimmetrico. L'armonioso gioco di contrasti rende Percy brillante protagonista dello spazio abitativo contemporaneo, ideale posizionato al centro della stanza.

Dynamic and linear, Percy stands out for its refined soul and bold personality. The sharped geometrical lines are balanced by the softness of the seat covers, quilted in a unique asymmetrical design. The harmonious play of contrasts makes the Percy a stunning star of the contemporary living space, ideally placed in the middle of the room.



mod. Percy  
v. 246-520-309

mod. Manfi - coffee tables  
v.1515

mod. Kea - ottoman  
v.504

mod. Dana - armchairs  
v. 105 - 105

mod. Manfi - coffee tables  
v. 1707



Percy\_



*mod. Percy*  
v. 304

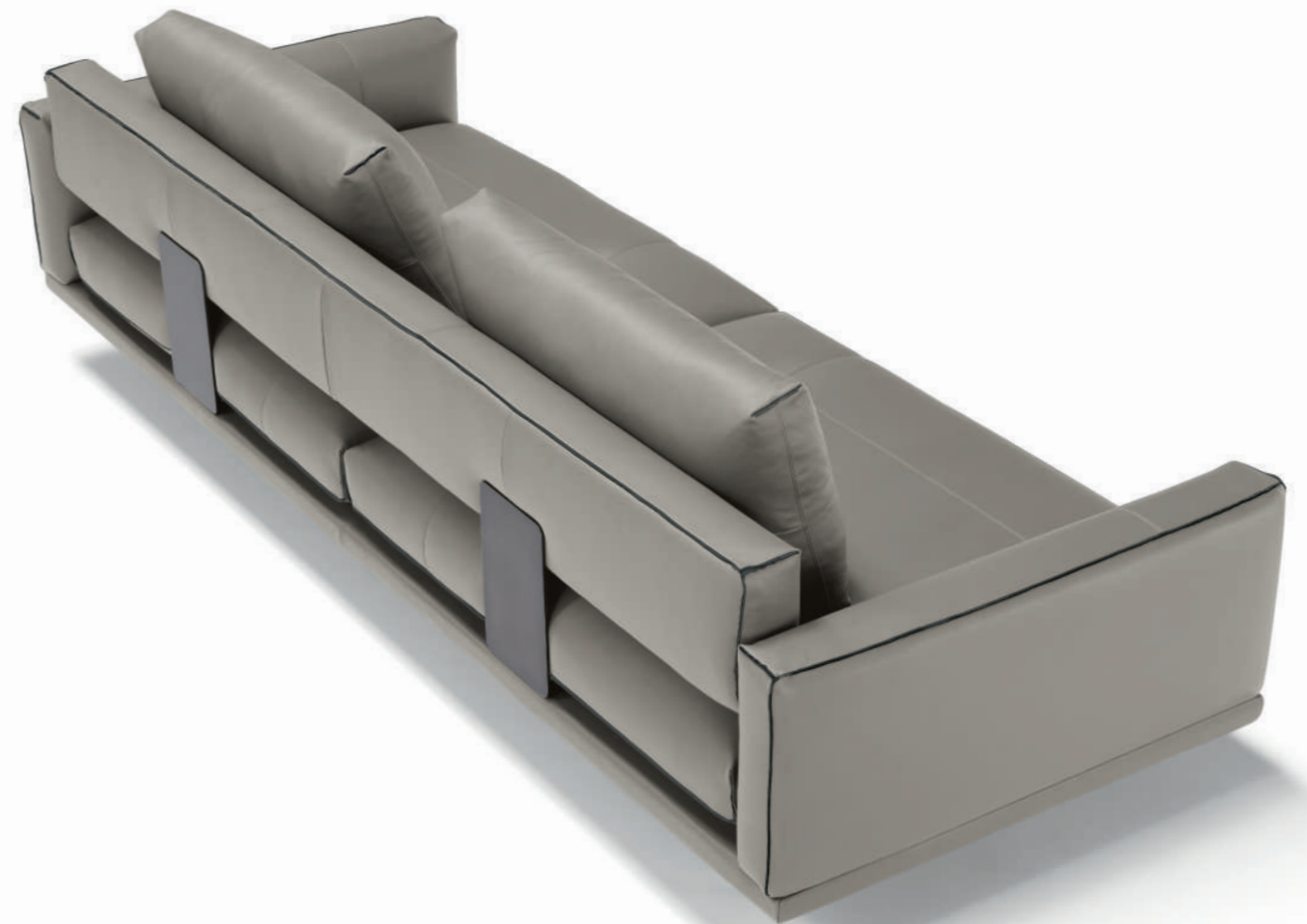

Percy\_



mod. Percy  
v. 310 - 303 - 518



embrace the backlight and take in its charm

## Panuma\_

Il divano Panuma si ispira ai petali di un fiore con lo schienale e i bracciali sagomati che si aprono delicatamente a ventaglio, come una grande corolla. Un abbraccio avvolgente accentuato dalle imbottiture generose e dalla seduta, confortevole e accogliente. La cura sartoriale nella lavorazione si rivela nelle cuciture profonde in verticale che scolpiscono i volumi di schienale e braccioli, modellandoli in forme piene e morbide. Il risultato estetico è elegante e raffinato.

The Panuma sofa is inspired by the petals of a flower with the shaped backrest and armrests that open gently like a fan, similar to a corolla. An enveloping embrace highlighted by the generous padding and the comfortable and welcoming seat. The sartorial care in the workmanship is emphasized in the deep vertical stitching that sculpts both the backrest and armrests, modelling them into full and soft shapes. The aesthetic result is elegant and refined.





mod. Panuma  
v.308

mod. Scott - armchairs  
v.105 - 105

mod. Panuma  
v. 310 - 229

mod. Tarkin - ottoman | coffee tables  
v. 505 - 502 | 1515

mod. Manfi - coffee tables  
v. 1707

Panuma\_





*mod. Panuma*  
v. 310 - 229

*mod. Scott - armchair*  
v. 105

*mod. Tarkin - ottoman | coffee tables*  
v. 505 - 502 | 1515

*mod. Manfi - coffee tables*  
v. 1707

Panuma\_



*mod. Panuma  
v.230 - 309*





mod. Panuma  
v.308

Panuma\_



*mod. Panuma*  
v.308



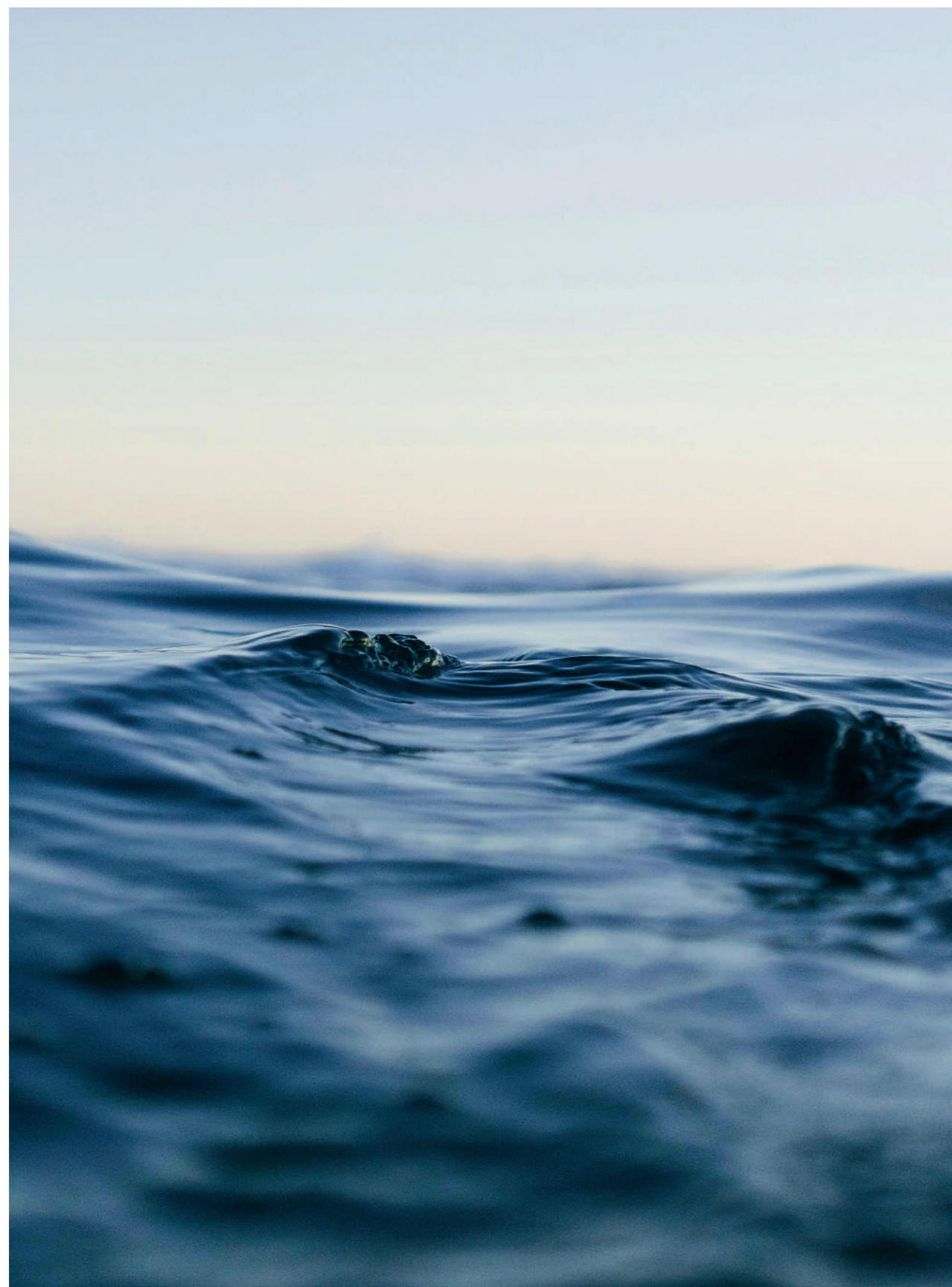

the infinite beauty of the sea and its colors

## Geo\_

Classico e contemporaneo allo stesso momento, il richiamo di una lavorazione artigianale in una trapuntatura unica e ricercata, che rende il modello Geo un divano adattabile ad ogni stile.

Geo is the perfect combination of classic and contemporary. The quilting and the handcrafted workmanship make this sofa unique and versatile. A perfect match to fit in any environment with elegance.



*mod. Geo*  
v.308  
*mod. Muzzle - coffee tables*  
v.1712 - 703  
*mod. Leia - ottoman*  
v.504 - 500

*mod. Abbracci - armchairs*  
v.102 - 101  
*mod. Muzzle - coffee tables*  
v.703

Geo\_





Geo\_



*mod. Geo*  
v.308



## Globo\_

Globo è un sofà caratterizzato da un aspetto informale e dalle linee arrotondate di schienale e braccioli che accentuano morbidezza e dinamicità. La seduta è soffice e profonda. La raffinata trapuntatura del rivestimento è visibile a 360° su tutta la superficie e lo rende perfetto da ammirare al centro della stanza.

Globo, with its informal look and rounded lines of the backrest and armrests that accentuate softness and dynamism. The seat is soft and deep. The refined quilting is visible 360° over the entire surface and makes it perfect to be marvelled in the center of the room



mod. Globo  
v.230 - 309

mod. Manfi - coffee tables  
v.1502 - 1704

mod. Kea - ottoman  
v.504 - 500

mod. Dana - armchair  
v.105

Globo\_





Globo\_



*mod. Globo  
v.308*





nature and its colours is inconceivable without trees.

## Bon Bon\_

Bon Bon è una presenza che caratterizza gli ambienti con personalità e leggerezza. Il design, elegante e al tempo stesso informale, evoca la forma di una caramella arrotolata, con il particolare estetico di lacci in pelle abbottonati ai lati che stringono i braccioli, esaltando l'unicità della lavorazione artigianale.

Bon Bon characterizes the environments with personality and lightness. The design, elegant and informal, evokes the shape of a rolled candy, with the aesthetic detail of leather laces buttoned on the sides that tighten the armrests, enhancing the uniqueness of the artisan workmanship.





mod. Bon Bon  
v.308 - 310 - 243

mod. Scott - armchairs  
v.105 - 105

mod. Manfi - coffee tables  
v.1515 - 1704 - 1707 - 1502

Bon Bon\_



mod. Bon Bon  
v.308

Bon Bon\_



*mod. Bon Bon  
v.304*







mod. Bon Bon UP  
v.310 - 243  
mod. Scott - armchairs  
v.105 - 105  
mod. Manfi - coffee tables  
v.1515 - 1704 - 1707 - 1502

## Bon Bon Up\_



*mod. Bon Bon Up*  
v.244 - 309

Bon Bon Up con le sue spalliere removibili raccoglie il fascino del modello Bonbon ma ne esalta ancor di più confort.

With its removable backs it inherits the charm of model Bon Bon while enhancing the comfort.





shaped by time, the extraordinary power of nature

## Sospiro\_

Elegante e scenografico Sospiro è un divano dall'estetica leggera e armoniosa, con volumi morbidi e scultorei, privi di spigoli. Elemento caratteristico è la forma arrotondata di spalliera e braccioli che evoca quella di sassi levigati dal tempo e dal lento agire degli elementi della natura.

Elegant and scenographic Sospiro is a sofa with a light and harmonious aesthetic, with soft and sculptural volumes, without sharp edges. A characteristic element is the rounded shape of the backrest, the armrests that evokes smoothed stones by time and the slow action of the elements of nature.





*mod. Scott - armchairs*  
v.105 - 105

*mod. Sospiro*  
v.230 - 3005  
*mod. Krisa - coffee tables*  
v.1707 - 1502 - 1515

Sospiro\_





mod. Sospiro  
v.230 - 3005  
mod. Krisa - coffee tables  
v.1707 - 1502 - 1515

Sospiro\_



Sospiro\_



*mod. Sospiro*  
v. 230 - 3005



Sospiro\_





mod. Sospiro  
V.306 - 419 - 305

mod. Abbracci - aranchairs  
V.102 - 101

mod. Manfi - coffee table  
V.1707 - 1515 - 1704 - 1707

Sospiro\_





the beauty of light through the clouds

## Nuvola\_

Divano in pelle nabuk soffice come una Nuvola, dalla spiccata comodità e dalle forme avvolgenti, l'ideale per i tuoi momenti di relax. Nuvola offre un'esperienza unica di comfort assoluto.

Nubuck leather sofa soft as a Cloud, with a marked comfort and enveloping shapes, ideal for your moments of relaxation. Nuvola offers a unique experience of absolute comfort.





mod. Nuvola  
v.114 - 113

mod. Muzzle - coffee tables  
v.703 - 1712 - 703

mod. Leia - ottoman  
v.500 - 504

Nuvola\_





*mod. Abbracci - armchairs*  
v.102 - 101

*mod. Nuvola*  
v.114 - 113  
*mod. Muzzle - coffee tables*  
v.703 - 1712 - 703  
*mod. Leia - ottoman*  
v.500 - 504

Nuvola\_



*mod. Nuvola*  
v. 114 - 113



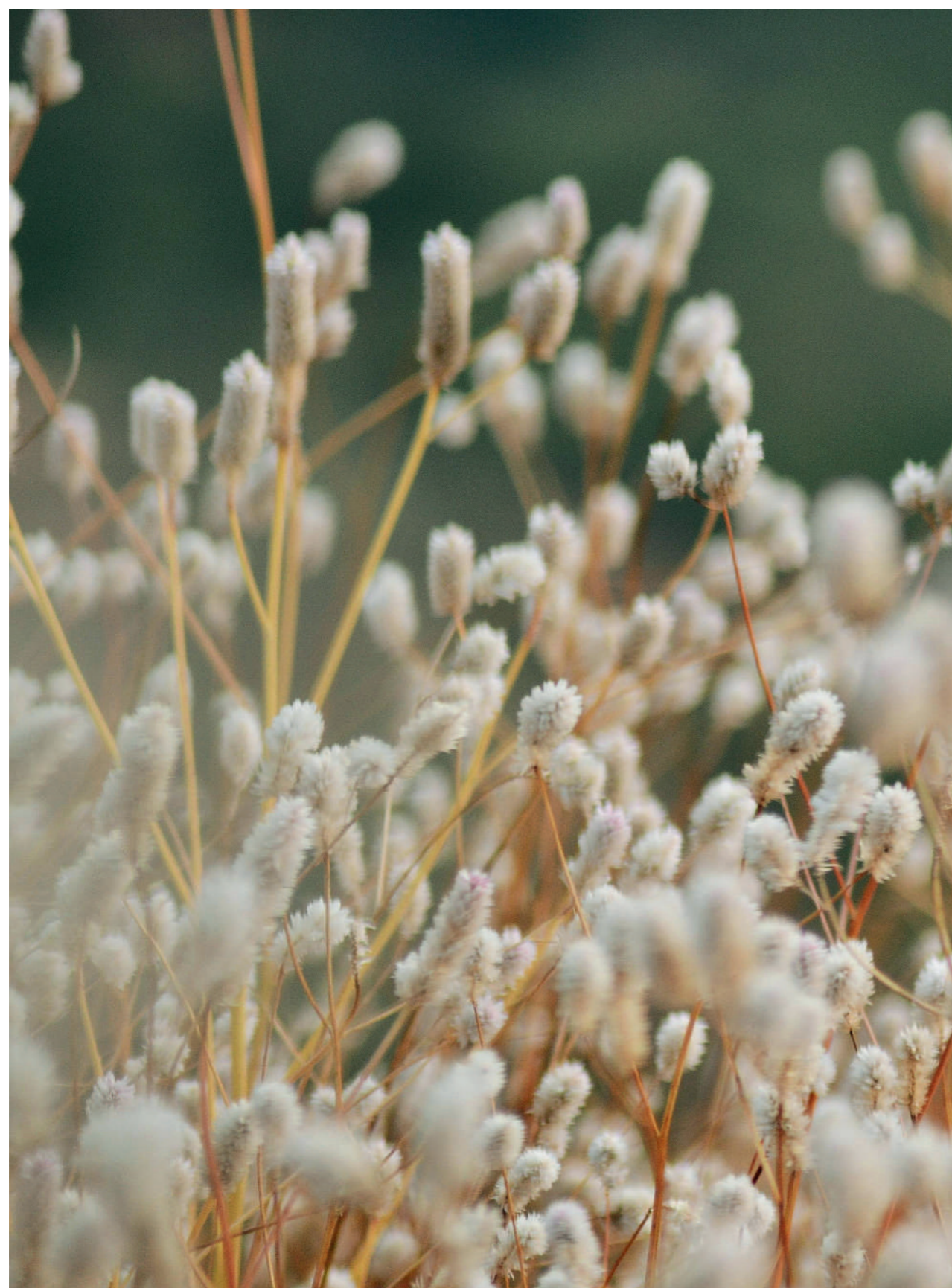

Nature with its touch of softness and elegance.

## Chicca\_

Concepito come un avvolgente e soffice abbraccio nel quale rifugiarsi in ogni momento della giornata, il modello componibile Chicca si distingue per le sue forme sinuose e tondeggianti, esaltate dal particolare gioco di cuciture che contribuisce con carattere a definirne i volumi.

Designed and shaped with a soft and enveloping embrace in which to take shelter at any time of the day, Chicca stands out for its sinuous and rounded shapes, enhanced by the particular play on stitchings.



mod. Chicca  
v.249 - 125 - 400 - 125

mod. Chicca - armchair  
v.125  
mod. Tarkin - coffee table | ottoman  
v.1515 | 502 - 515

Chicca\_





*mod. Chicca*  
v.249 - 125 - 400 - 125  
*mod. Muzzle - coffee tables*  
v.703 - 1711  
*mod. Tarkin - coffee table | ottoman*  
v.1515 | 502

Chicca\_



mod. Chicca  
v.249 - 125 - 400 - 125

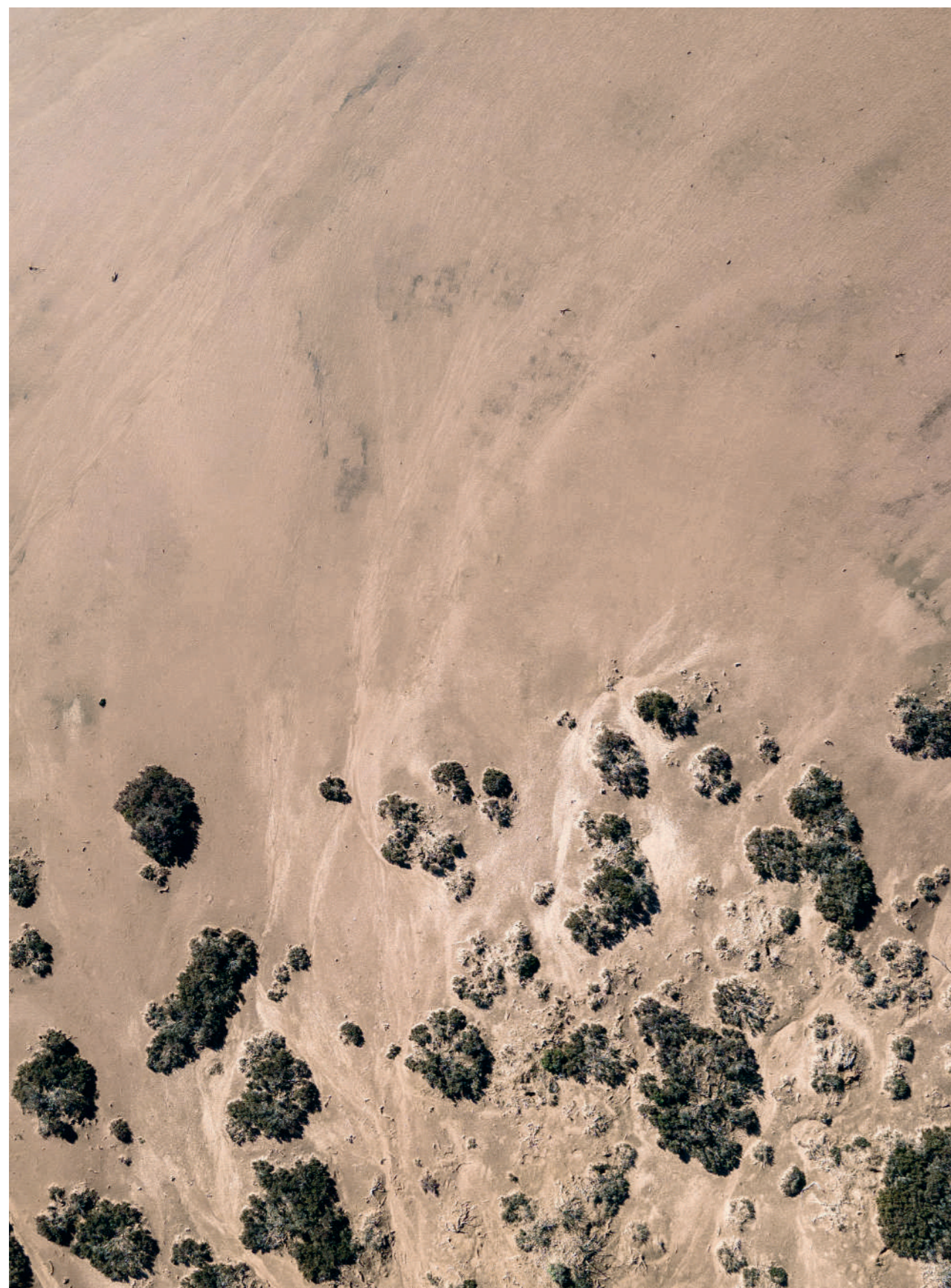

The arid soil is a source of colors

## Sipario\_

Design ricercato e dallo spirito accogliente per il modello angolare Sipario. Caratterizzato dall'andamento curvilineo della solida struttura in legno su cui sono alloggiate le sedute, è al contempo espressione di dinamismo grazie ai cuscini volanti in piuma d'oca che ne definiscono la spalliera.

Refined design and a welcoming spirit for the Sipario corner model. Characterized by the curved shape of the solid wooden structure on which the seats are placed, at the same time an expression of dynamism thanks to the loose goose down cushions that define the backrest.





mod. Sipario  
v.202 - 201 - 300  
mod. Tarkin - coffee table | ottoman  
v.1515 | 515 - 502  
mod. Manfi - coffee table  
v.1707

Sipario\_



mod. Sipario  
v.300  
mod. Tarkin - ottoman  
v.515 - 502



Sipario\_



mod. Sipario  
v.314 - 213



The green leaf symbol of rebirth and life

## Morfeo\_

Appeal contemporaneo e design caratterizzato dalla spiccata linearità sono i tratti distintivi del modello, un perfetto compromesso tra estetica e comfort. Personalizzabile negli abbinamenti dei rivestimenti, Morfeo si distingue infine per la base aperta ed ariosa, sollevata da terra di ben venti centimetri.

Contemporary design characterized by marked linearity are the distinctive features of the model, a perfect compromise between aesthetics and comfort. It can be customized in various combinations of the coverings, Morfeo is distinguished by the open and airy base, raised 20cm from the floor.





Morfeo\_





*mod. Morfeo*  
v.246 - 309  
*mod. Perla - armchairs*  
v.104

*mod. Muzzle - coffee table | ottoman*  
v.1711 - 1712 - 703 | 519

Morfeo\_



*mod. Morfeo*  
v.310 - 381



Nature shapes lights and shadows

## Modula\_

Espressione di versatilità e dinamismo, il divano Modula, è il risultato di una sapiente combinazione di versioni. Il modello si sviluppa linearmente in una armonia di differenti profondità.

Modula is an expression of versatility and dynamism. A result of a clever combination of modules. The model is developed in a linear fashion, in harmony with different seat depths.



*mod. Modula*  
v.310 - 518 - 309  
*mod. Ember - armchair*  
v.104

*mod. Muzzle - coffee table*  
v.1711 - 703  
*mod. Leia - coffee tables | ottoman*  
v.1504 - 501

Modula\_





Modula\_



mod. Modula  
v.310 - 249 - 721 - 245



Modula\_





mod. Módula  
v.310 - 245 - 722  
mod. Muzzle - armchair  
v.104

mod. Muzzle - coffee table  
v.1711 - 703



Modula\_



*mod. Modula*  
v.206 - 722 - 243



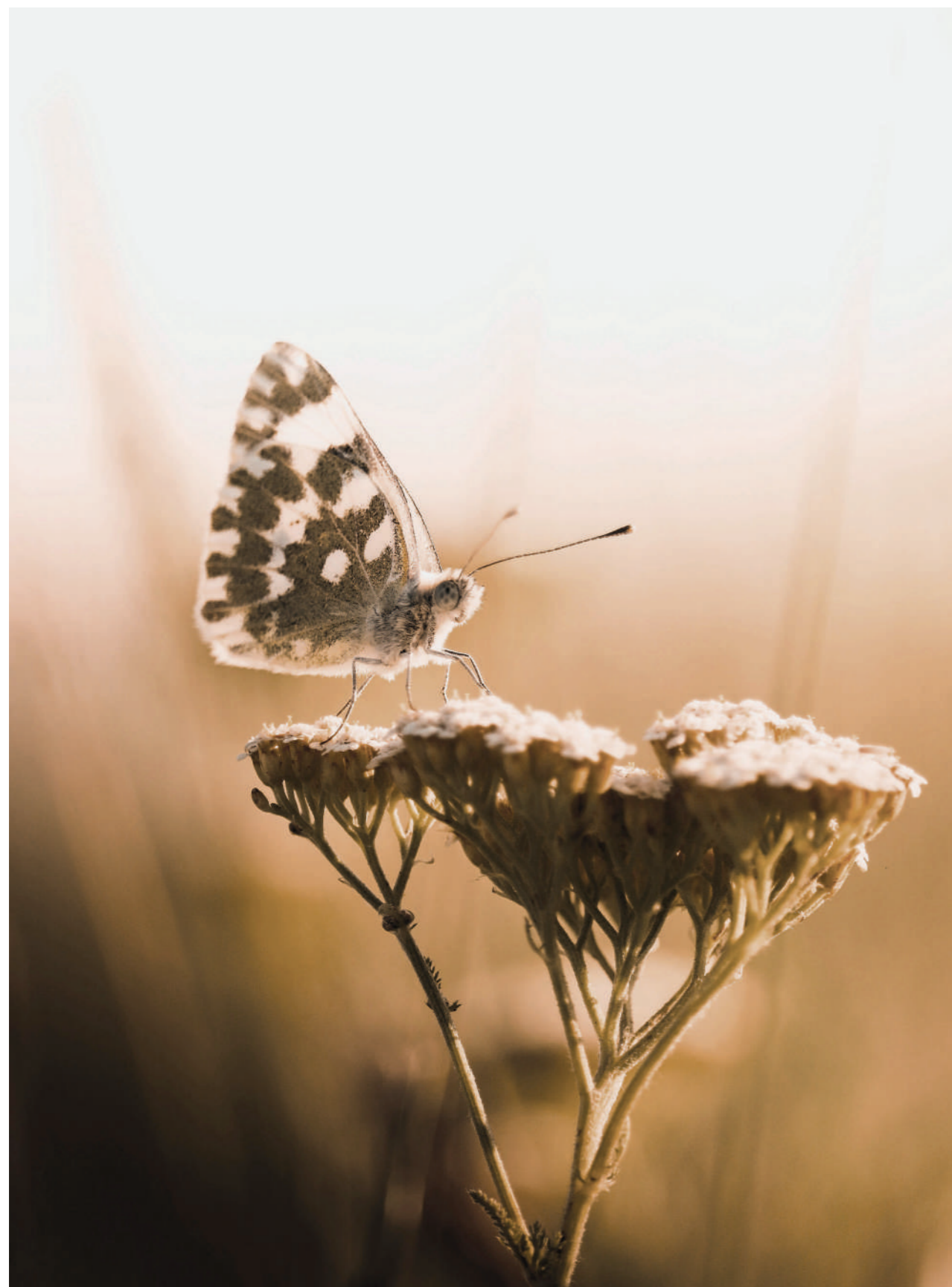

the delicacy of a butterfly and its harmony of colors

## Dana\_

Volumi pieni e morbidi per la poltrona Dana che unisce la raffinatezza nella lavorazione sartoriale all'estremo comfort. Solida e dalle generose rotondità, il design è caratterizzato dal dettaglio di raffinate fasce di pelle cucite in entrambi i lati, a collegare la seduta alla spalliera.

The Dana armchair, combining sophisticated craftsmanship with comfort. Solid with surrounding shapes, the design is embellished by details such as the refined leather straps sewn onto both sides, linking the seat to the backrest.



*mod. Dana - armchairs  
v. 105 - 105*

*mod. Manfi - coffee tables  
v. 1707*

*mod. Kea - ottoman  
v. 504*

Dana\_



Dana\_



*mod. Dana*  
v.100

## Muzzle\_

Definita da una seduta avvolgente, rivestita in pregiato velluto grigio platino la cui esclusiva lavorazione trapuntata crea un raffinato gioco tridimensionale di luci e ombre, la poltrona a pozzetto Muzzle è la quintessenza della cura artigianale unita al comfort.

With a defined and enveloping seat, upholstered in fine platinum grey velvet whose exclusive quilted workmanship creates a refined three-dimensional play of light and shadows, the Muzzle tub chair is the quintessence of artisan craftsmanship combined with comfort.



Muzzle\_



mod. Muzzle - armchair  
v. 194  
mod. Muzzle - coffee table  
v. 703

Muzzle\_



*mod. Muzzle*  
*v.104*

## Abbracci\_

Abbracci è una poltrona che può vivere da sola oppure trasformarsi in originale divano a due posti. La spalliera, leggermente arrotondata, ti avvolge come un tenero abbraccio, regalando un momento di intenso rilassamento.

Abbracci is a stand-alone piece or an original two-seater sofa. The slightly rounded backrest envelops the seat like a tender embrace, offering a cuddle and a moment of relax.



Abbracci\_



mod. Abbracci - armchair  
v.102 - 101  
mod. Manfi - coffee table  
v.1707

Abbracci\_



*mod. Abbracci*  
v.102 - 101



Swing\_



Swing\_



mod. Swing - armchair  
v.111 - 111  
mod. Krisa - coffee table  
v.1707

# Swing\_



mod. Swing  
v.111

*Poltrona confortevole ed elegante con movimento girevole e oscillante, rivestita in pregiata pelle nubuck con base in acciaio nero opaco.*

*Comfy and elegant armchair with swivel and swinging movement, covered in fine nubuck leather with matt black steel base.*



*Movimento girevole  
Swivel movement*



*Movimento oscillante  
Swinging movement*

## Ember\_

Spirito giocoso e versatile per la deliziosa poltroncina a pozzetto Ember. Ideale per definire un angolo relax, arreda con agilità qualsiasi spazio - anche il più contenuto - che richieda un'oasi di comfort.

Playful and versatile spirit for the delightful Ember tub chair. Ideal for a relaxation spot, it easily furnishes any space - even the smallest - that requires an oasis of comfort.



Ember\_



mod. Ember - armchair  
v.104 - 104  
mod. Muzzle - coffee table  
v.703

Ember\_



*mod. Ember*  
v.104

## Scott\_

Dal forte appeal contemporaneo e destinata ad arredare con carattere ogni ambiente, la poltrona Scott si distingue per la sua particolare forma angolare senza braccioli, al contempo ricercata ed accogliente.

With a contemporary appeal and designed to furnish any room with character, the Scott armchair stands out for its particular angular shape without armrests, at the same time refined and welcoming.



Scott\_



mod. Scott - armchair  
v.105 - 105

Scott\_



*mod. Scott  
v.105*



## Perla\_

Elegante e confortevole, Perla è una poltrona dal design morbido e lo schienale arrotondato che evoca la forma di una conchiglia. Il rivestimento è impreziosito dal gioco delle cuciture verticali e dal bordino che delinea il profilo donando una nota di disinvolta raffinatezza.

Elegant and comfortable, Perla is an armchair with a soft design and a rounded backrest that evokes the shape of a shell. The coverage is embellished by the play of vertical stitching and the piping that outlines the profile, giving a note of casual refinement.



Perla\_



mod. Perla - armchair  
v.104  
mod. Muzzle - coffee table  
v.703

Perla\_



*mod. Perla*  
*v.104*

## Krisa\_

La combinazione ideale di forme e materiali, ripiani in gres e legno, strutture rivestite in tessuto e pelle e dettaglio in acciaio, tantissime combinazioni di colori per ogni esigenza di gusto.

Ideal combination of shapes and materials, stoneware and wood shelves, structures covered in fabric and leather, steel details, many color combinations to your liking.



Krisa\_



mod. Krisa - coffee table  
v.1502

Krisa\_



mod. Krisa  
v. 1502 - 1515 - 1707



## Tarkin\_

Dalle forme essenziali e rivestiti nelle tonalità neutre degli elementi naturali, i complementi d'arredo Tarkin si caratterizzano per il design arrotondato, ispirato al profilo dei ciottoli levigati dalle acque di un fiume.

Essential shapes covered with neutral tones and natural elements, Tarkin furnishing accessories are characterised by a rounded design, inspired by the profile of pebbles smoothed by the waters of a river.



Tarkin\_



mod. Tarkin - coffee table | ottoman  
v.1515 | 502

Tarkin\_



*mod. Tarkin*  
v. 515 - 502 - 1515



## Manfi\_

I tavolini Manfi sono di forma circolare, disponibili in quattro diverse varianti di altezza e diametro e si armonizzano con facilità in ogni ambiente. Caratterizza il design il tondino di supporto in metallo e il rivestimento in pelle o in tessuto.

Manfi coffee tables are of circular shapes, available in four different heights and diameters, that can be blended in any environment. The design is characterized by the metal support rod and the leather or fabric covering.



Manfi\_



mod. Manfi - coffee table  
v.1515 - 1704

Manfi\_



*mod. Manfi*  
v.1701



*mod. Manfi*  
v. 1502 - 1515 - 1707 - 1704



## Kea\_

I pouf Kea sono proposti in tre misure, con la seduta imbottita e il rivestimento in tessuto o pelle. Segno estetico decorativo è il laccio in pelle posizionato nello spigolo, in cinque possibili varianti di colore, per donare un tocco informale e originale ad ogni arredo.

Kea stools are available in three sizes, with a padded seat in fabric or leather. A decorative aesthetic feature is the leather lace positioned at the corner, in five different color options, to give an informal and original touch to any decor.



Kea\_



mod. Manfi - coffee table  
v.1704

mod. Kea - ottoman  
v.504 - 500

Kea\_



*mod. Kea  
v. 501*



*mod. Kea  
v. 500 - 504*



## Muzzle\_

I tavolini e pouff Muzzle dalle sagome irregolari con spigoli arrotondati e differenti altezze, racchiudono in loro la massima versatilità e facilità di utilizzo.

Muzzle tables and stools with irregular shapes and rounded edges, available in different heights, enclose the maximum versatility and ease of use.



Muzzle\_



mod. Muzzle - coffee table  
v.1711

Muzzle\_



*mod. Muzzle*  
v. 703



*mod. Muzzle*  
v. 519 - 703 - 1712



## Leia\_

Avvolti in un'ampia fascia chiusa da due bottoni decorativi, i pouf e i tavolini da caffè Leila imitano con spirito irriverente il polsino di una camicia. Il loro stile però è tutt'altro che formale! Giocando con abbinamenti inediti di colori, rivestimenti e trame, sapranno regalare alla zona living un tocco di dinamismo e vivacità ed insieme accogliere ogni momento conviviale e di relax.

coffee tables irreverently imitate the shirt cuffs. However, their style is anything but formal! Playing with unusual combinations of colors, coverings and textures, they will be able to give the living area a touch of dynamism and liveliness and at the same time welcome every convivial and relaxing moment.



Leia\_



mod. Leia - coffee table | ottoman  
v.1504 | 501

Leia\_



*mod. Leia  
v. 504*



*mod. Leia  
v. 504 - 1501*





Schede tecniche  
Technical sheet

**Divani** / Sofas

**Poltrone** / Armchairs

**Complementi** / Accessories

**Cuscini** / Pillows

# Bon Bon\_

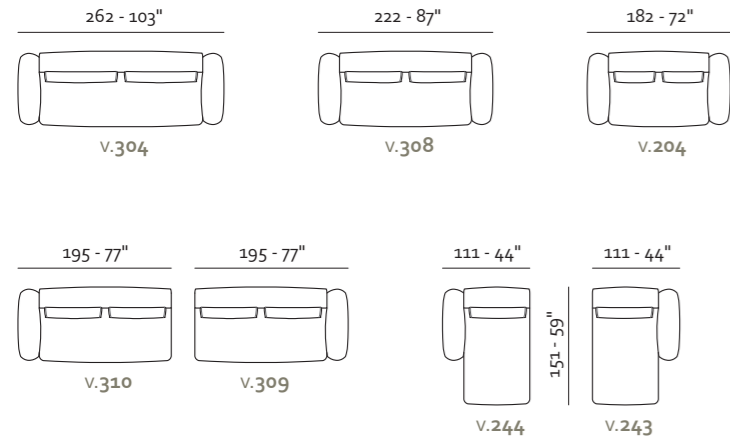

## Esempi di componibilità - Sectionals examples - Exemples de compositions - Ejemplos de modularidad

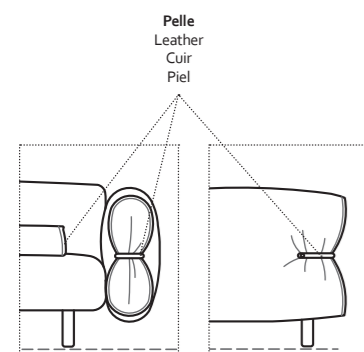
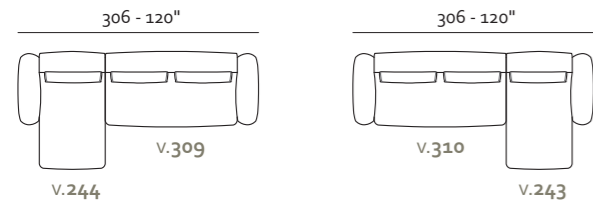

patented model

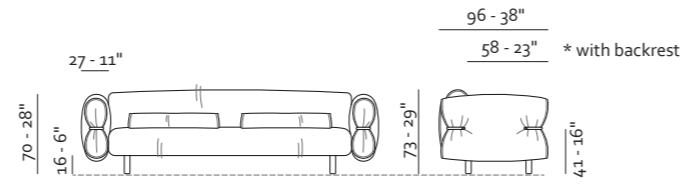

- Rivestimento  
Pelle / Tessuto
- Imbottitura  
BRACCIOLI / Poliuretano espanso  
SEDUTA / Poliuretano espanso  
SPALLIERA / Poliuretano espanso - Micromax
- Opzioni Cucitura a contrasto
- Comfort Standard
- Piedi Metallo
- Struttura Telaio in legno

- Coverings  
Leather / Fabric
- Filling  
ARMS / Foam  
SEAT CUSHION / Foam  
BACK CUSHION / Foam - Micromax
- Options Contrast stitching
- Comfort Standard
- Legs Metal
- Structure Wooden frame

- Revêtement  
Cuir / Tissu
- Rembourrage  
ACCOUDOIRS / Mousse  
ASSISE / Mousse  
DOSSIER / Mousse - Micromax
- Options Coutures contrastées
- Confort Standard
- Pieds Metal
- Structure Structure en bois

- Revestimiento  
Piel / Tela
- Imbottitura  
APOYABRAZOS / Poliuretano expandido  
SENTADA / Poliuretano expandido  
RESPALDO / Poliuretano expandido - Micromax
- Opciones Costura en contraste
- Confort Estándar
- Pies Metal
- Estructura Estructura en madera

- Finitura piedi / Legs finishes  
Finition de pieds / Acabados de pies



# Bon Bon Up\_

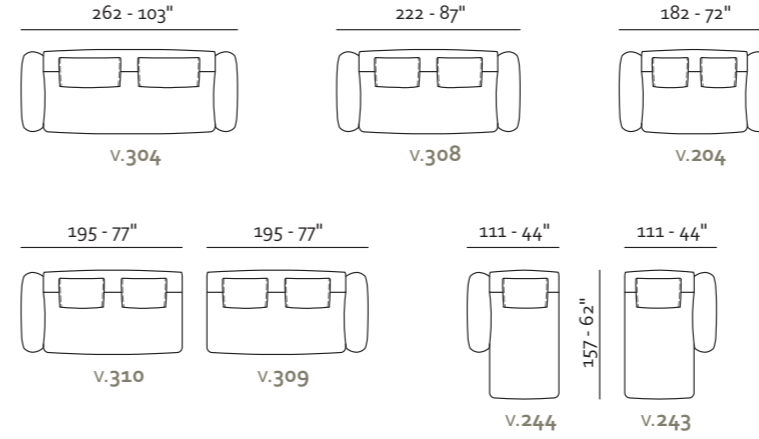

## Esempi di componibilità - Sectionals examples - Exemples de compositions - Ejemplos de modularidad

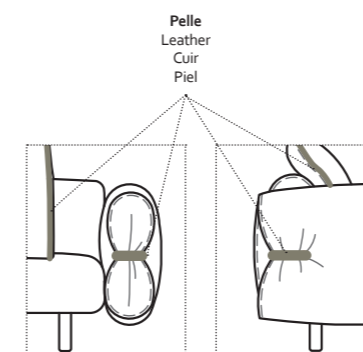
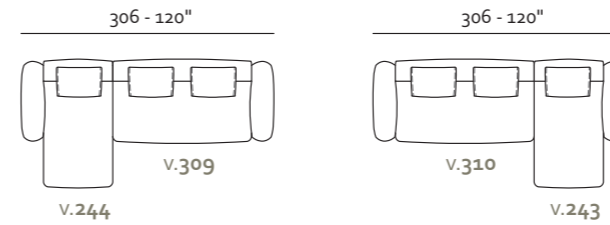

patented model

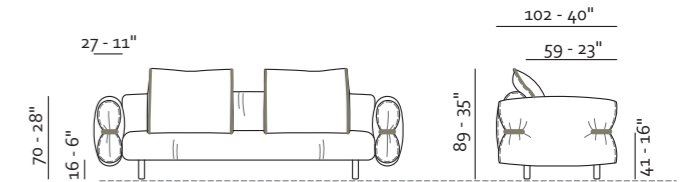

- Rivestimento  
Pelle / Tessuto
- Imbottitura  
BRACCIOLI / Poliuretano espanso  
SEDUTA / Poliuretano espanso  
SPALLIERA / Poliuretano espanso - Piuma
- Opzioni Cucitura a contrasto
- Comfort Standard
- Piedi Metallo
- Struttura Telaio in legno

- Coverings  
Leather / Fabric
- Filling  
ARMS / Foam  
SEAT CUSHION / Foam  
BACK CUSHION / Foam - Feather
- Options Contrast stitching
- Comfort Standard
- Legs Metal
- Structure Wooden frame

- Revêtement  
Cuir / Tissu
- Rembourrage  
ACCOUDOIRS / Mousse  
ASSISE / Mousse  
DOSSIER / Mousse - Plumes
- Options Coutures contrastées
- Confort Standard
- Pieds Metal
- Structure Structure en bois

- Revestimiento  
Piel / Tela
- Imbottitura  
APOYABRAZOS / Poliuretano expandido  
SENTADA / Poliuretano expandido  
RESPALDO / Poliuretano expandido - Plumes
- Opciones Costura en contraste
- Confort Estándar
- Pies Metal
- Estructura Estructura en madera

- Finitura piedi / Legs finishes  
Finition de pieds / Acabados de pies



# Chicca\_

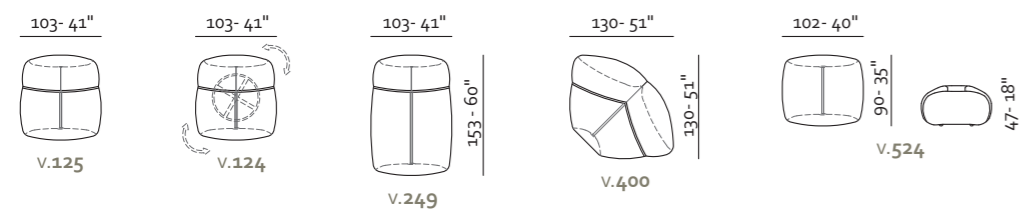

Esempi di componibilità - Sectionals examples - Exemples de compositions - Ejemplos de modularidad

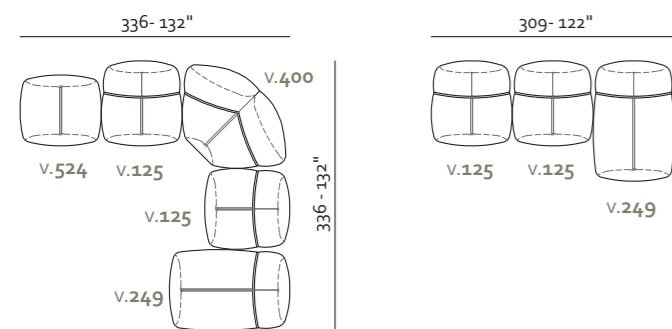

patented model

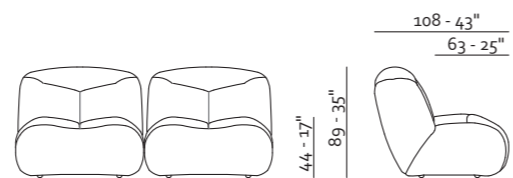

- Rivestimento  
Pelle / Tessuto
- Imbottitura  
BRACCIOLI / Poliuretano espanso  
SEDUTA / Poliuretano espanso  
SPALLIERA / Poliuretano espanso
- Opzioni Cucitura a contrasto
- Comfort Standard
- Piedi Plastica
- Struttura Telaio in legno

- Coverings  
Leather / Fabric
- Filling  
ARMS / Foam  
SEAT CUSHION / Foam  
BACK CUSHION / Foam
- Options Contrast stitching
- Comfort Standard
- Legs Plastic
- Structure Wooden frame

- Revêtement  
Cuir / Tissu
  - Rembourrage  
ACCOUDOIRS / Mousse  
ASSISE / Mousse  
DOSSIER / Mousse
  - Options Coutures contrastées
  - Comfort Standard
  - Pieds Plastique
  - Structure Structure en bois
- 
- Revestimiento  
Piel / Tela
  - Imbottitura  
APOYABRAZOS / Poliuretano expandido  
SENTADA / Poliuretano expandido  
RESPALDO / Poliuretano expandido
  - Opciones Costura en contraste
  - Comfort Estándar
  - Pies Plástico
  - Struttura Estructura en madera

# Geo\_

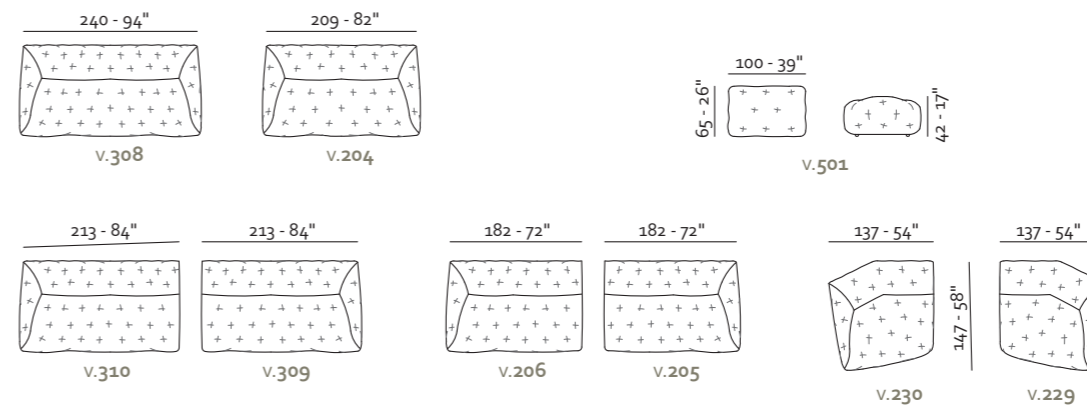

Esempi di componibilità - Sectionals examples - Exemples de compositions - Ejemplos de modularidad

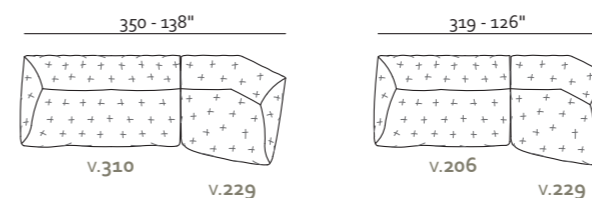

patented model

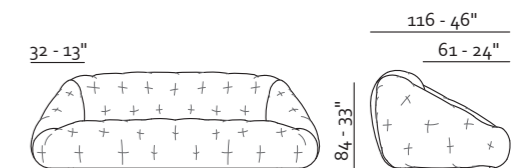

- Rivestimento  
Pelle / Tessuto
- Imbottitura  
BRACCIOLI / Poliuretano espanso  
SEDUTA / Poliuretano espanso  
SPALLIERA / Poliuretano espanso
- Opzioni Cucitura a contrasto
- Comfort Standard
- Piedi Plastica
- Struttura Telaio in legno

- Coverings  
Leather / Fabric
- Filling  
ARMS / Foam  
SEAT CUSHION / Foam  
BACK CUSHION / Foam
- Options Contrast stitching
- Comfort Standard
- Legs Plastic
- Structure Wooden frame

- Revêtement  
Cuir / Tissu
- Rembourrage  
ACCOUDOIRS / Mousse  
ASSISE / Mousse  
DOSSIER / Mousse
- Options Coutures contrastées
- Comfort Standard
- Pieds Plastique
- Structure Structure en bois

- Revestimiento  
Piel / Tela
- Imbottitura  
APOYABRAZOS / Poliuretano expandido  
SENTADA / Poliuretano expandido  
RESPALDO / Poliuretano expandido
- Opciones Costura en contraste
- Comfort Estándar
- Pies Plástico
- Struttura Estructura en madera

- Molle greche  
— Zig Zag springs  
— Sangles métalliques nozag  
— Muelles ondulados



# Globo\_



patented model

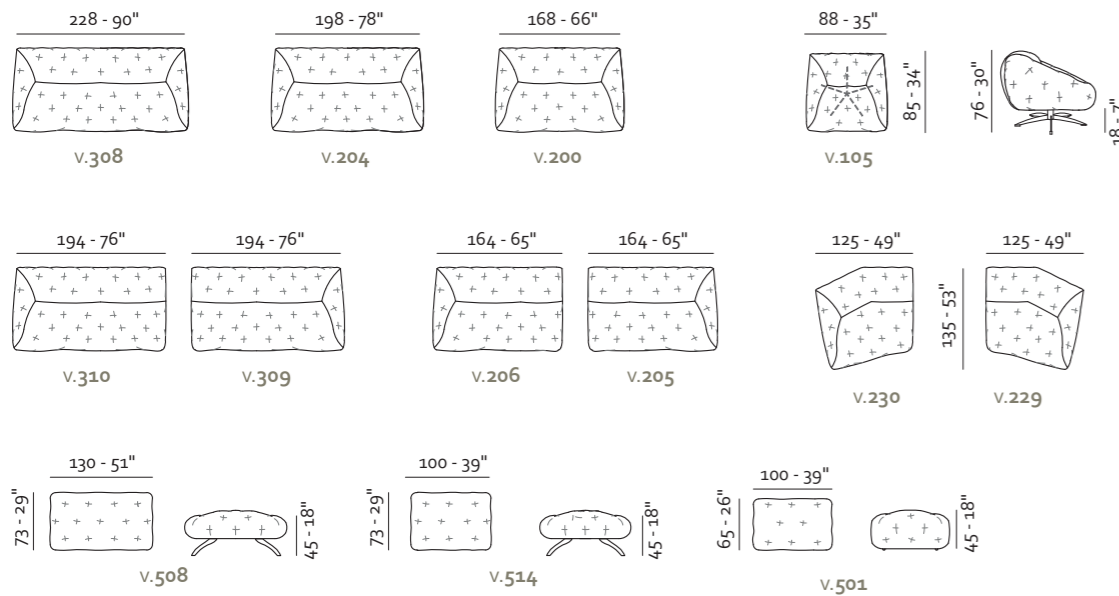
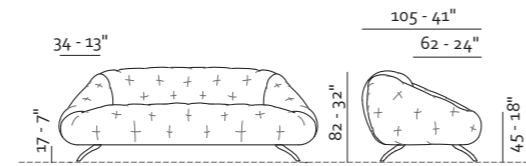

Esempi di componibilità - Sectionals examples - Exemples de compositions - Ejemplos de modularidad

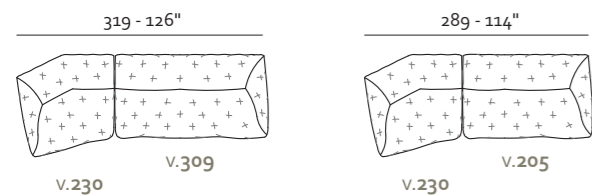

- Rivestimento  
Pelle / Tessuto
- Imbottitura  
BRACCIOLI / Poliuretano espanso  
SEDUTA / Poliuretano espanso  
SPALLIERA / Poliuretano espanso
- Opzioni Cucitura a contrasto
- Comfort Standard
- Piedi Metallo
- Struttura Telaio in legno

- Coverings  
Leather / Fabric
- Filling  
ARMS / Foam / Feather  
SEAT CUSHION / Foam  
BACK CUSHION / Foam
- Options Contrast stitching
- Comfort Standard
- Legs Metal
- Structure Wooden frame

- Revêtement  
Cuir / Tissu
- Rembourrage  
ACCOUDOIRS / Mousse  
ASSISE / Mousse  
DOSSIER / Mousse
- Options Coutures contrastées
- Comfort Standard
- Pieds Metal
- Structure Structure en bois

- Revestimiento  
Piel / Tela
- Imbottitura  
APOYABRAZOS / Poliuretano expandido  
SENTADA / Poliuretano expandido  
RESPALDO / Poliuretano expandido
- Opciones Costura en contraste
- Comfort Estándar
- Pies Metal
- Struttura Estructura en madera

- Molle greche  
— Zig Zag springs  
— Sangles métalliques nozag  
— Muelles ondulados



- Finitura piedi / Legs finishes  
Finition de pieds / Acabados de pies



# Match\_

patented model

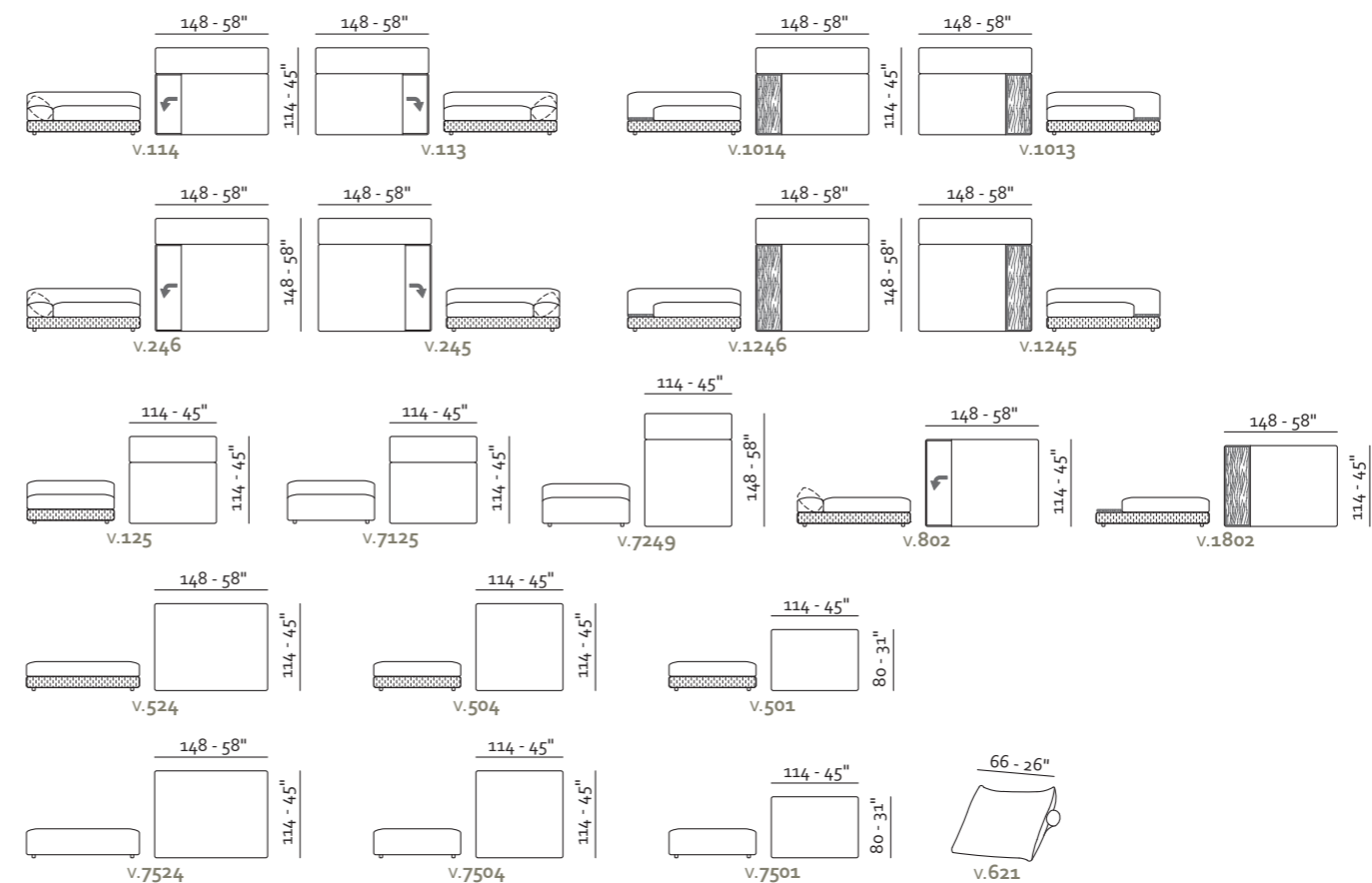
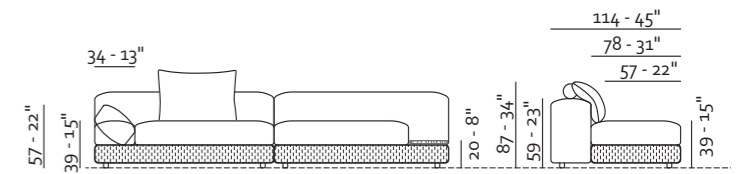

Esempi di componibilità - Sectionals examples - Exemples de compositions - Ejemplos de modularidad

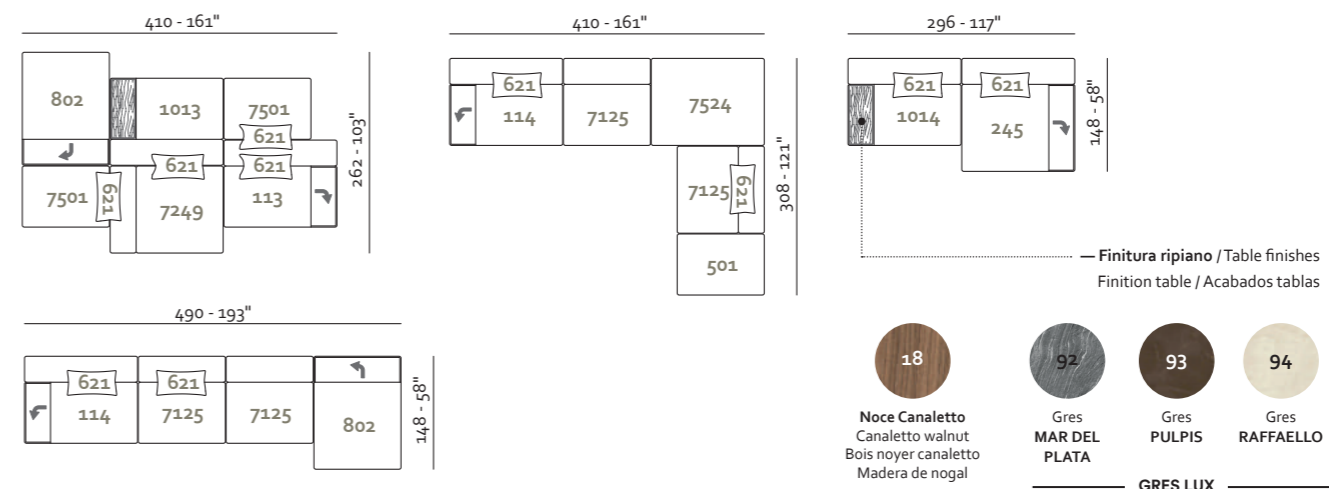

- Rivestimento  
Pelle / Tessuto
- Imbottitura  
BRACCIOLI / Poliuretano espanso  
SEDUTA / Poliuretano espanso  
SPALLIERA / Piuma
- Opzioni Cucitura a contrasto
- Comfort Standard / Rigido
- Piedi Plastica
- Struttura Telaio in legno

- Coverings  
Leather / Fabric
- Filling  
ARMS / Foam  
SEAT CUSHION / Foam  
BACK CUSHION / Feather
- Options Contrast stitching
- Comfort Standard / Hard
- Legs Plastic
- Structure Wooden frame

- Revêtement  
Cuir / Tissu
- Rembourrage  
ACCOUDOIRS / Mousse  
ASSISE / Mousse  
DOSSIER / Plumes
- Options Coutures contrastées
- Comfort Standard / Fermé
- Pieds Plastique
- Structure Structure en bois

- Revestimiento  
Piel / Tela
- Imbottitura  
APOYABRAZOS / Poliuretano expandido  
SENTADA / Poliuretano expandido  
RESPALDO / Pluma
- Opciones Costura en contraste
- Comfort Estándar / Duro
- Pies Plástico
- Struttura Estructura en madera

Cucitura a contrasto o in tinta  
Stitching tone on tone or contrast  
Coutures ton sur ton ou contrasté  
Costura en contraste o tono

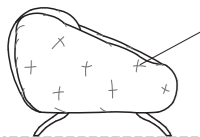

Le versioni che iniziano con il codice "7" hanno la seduta intera e possono essere realizzate solo in tessuto, le restanti versioni hanno la seduta con la base e quest'ultima può essere prodotta in tessuto o pelle.

Items starting with code "7" have the whole seat cushion and can only be made in fabric, while the remaining items have the seat with the base that can be made both in leather and fabric.

Les articles commençant par le code "7" ont le coussin d'assise monobloc et peuvent être fabriqués uniquement en tissu, tandis que les articles restants ont le siège avec la base qui peut être réalisée aussi bien en cuir qu'en tissu.

Las versiones con código "7" tienen el asiento entero es decir unico y sólo pueden fabricarse en tela, las otras versiones tienen asiento con base y estas se pueden fabricar en tela o piel.

# Modula\_



patented model

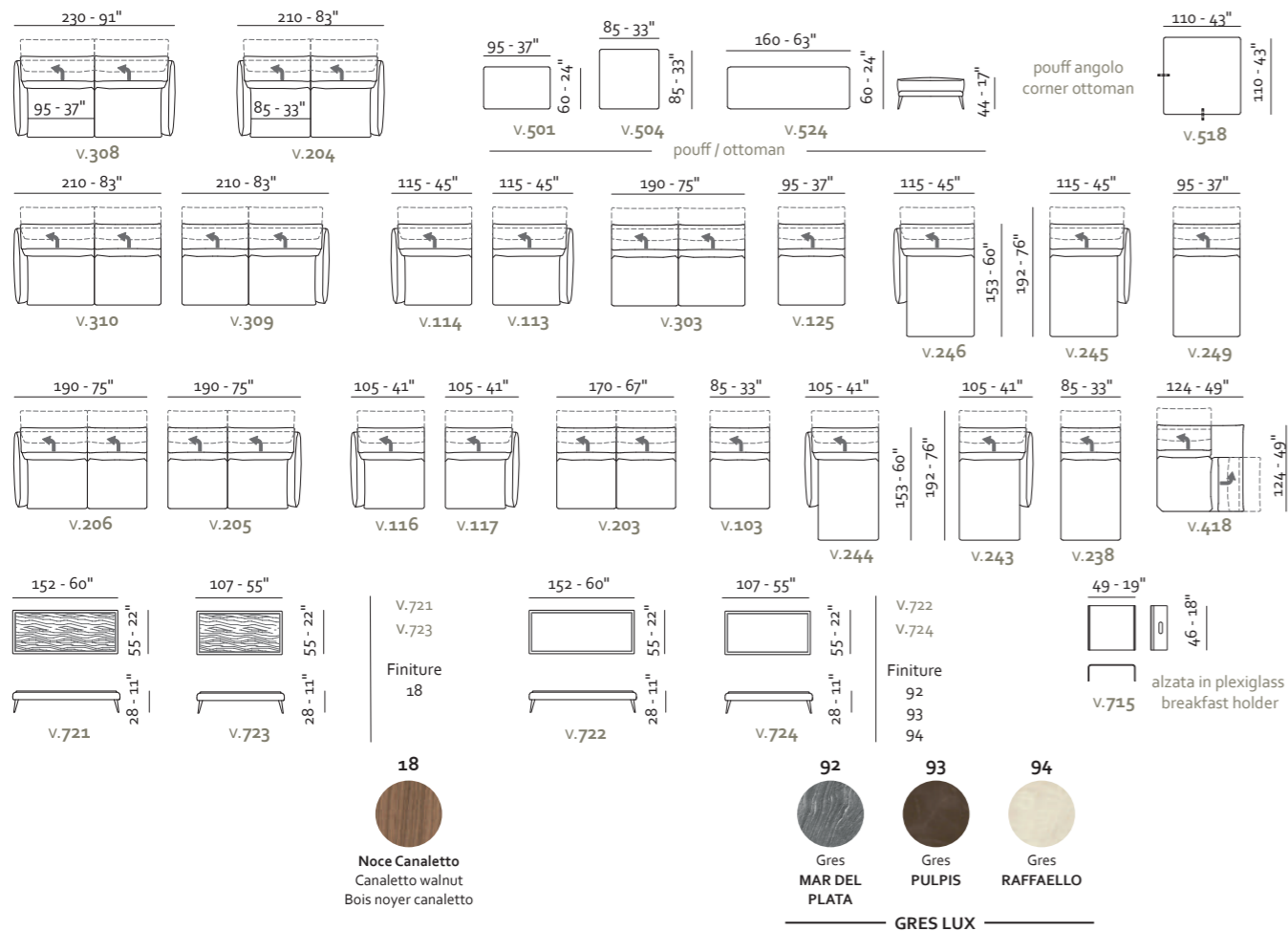
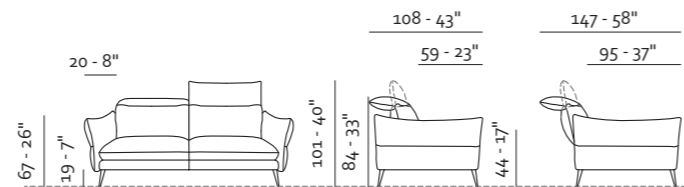

**18**  
Noce Canaletto  
Canaletto walnut  
Bois noyer canaletto

**92** Gres MAR DEL PLATA  
**93** Gres PULPIS  
**94** Gres RAFFAELLO  
**GRES LUX**

## Esempi di componibilità - Sectionals examples - Exemples de compositions - Ejemplos de modularidad

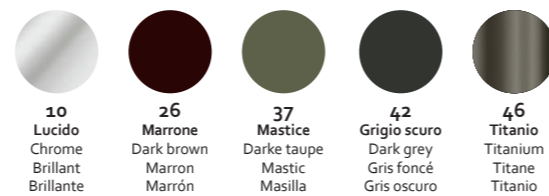
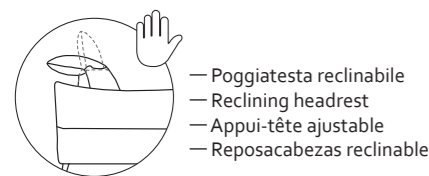
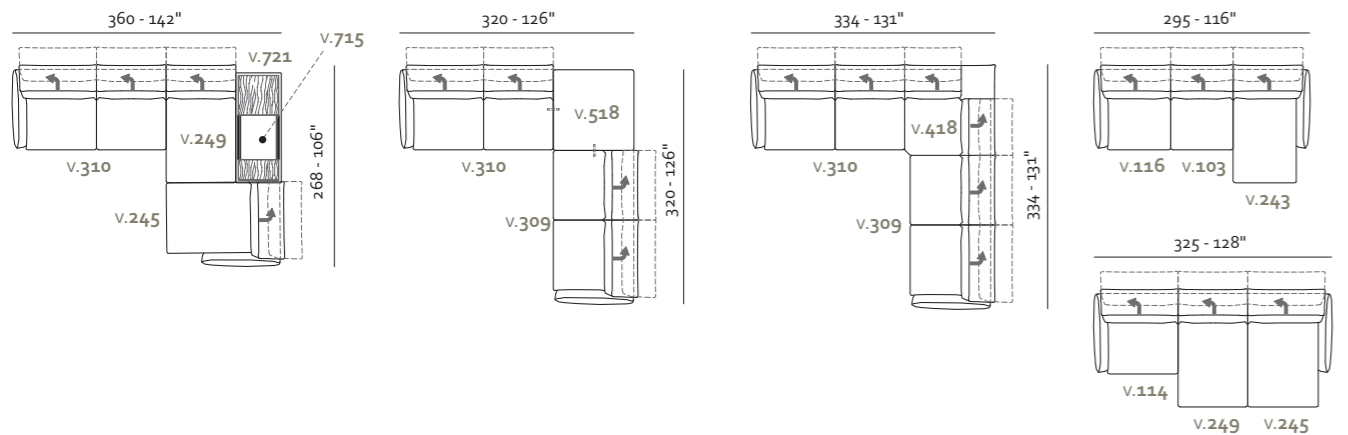

- **Rivestimento**  
Pelle / Tessuto
- **Imbottitura**  
BRACCIOLI / Poliuretano espanso / Piuma  
SEDUTA / Poliuretano espanso  
SPALLIERA / Poliuretano espanso
- **Opzioni** Cucitura a contrasto
- **Comfort Standard**
- **Piedi Metallo**
- **Struttura** Telaio in ferro e legno

- **Coverings**  
Leather / Fabric
- **Filling**  
ARMS / Foam / Feather  
SEAT CUSHION / Foam  
BACK CUSHION / Foam
- **Options** Contrast stitching
- **Comfort Standard**
- **Legs Metal**
- **Structure** Iron and wooden frame

- **Revêtement**  
Cuir / Tissu
- **Rembourrage**  
ACCOUDOIRS / Mousse / Plumes  
ASSISE / Mousse  
DOSSIER / Mousse
- **Options** Coutures contrastées
- **Confort Standard**
- **Pieds Metal**
- **Structure** Structure en bois et fer

- **Revestimiento**  
Piel / Tela
- **Imbottitura**  
APOYABRAZOS / Poliuretano expandido / Piuma  
SENTADA / Poliuretano expandido  
RESPALDO / Poliuretano expandido
- **Opciones** Costura en contraste
- **Confort Estándar**
- **Pies Metal**
- **Struttura** Estructura en madera y hierro

- **Finitura piedi / Legs finishes**  
Finition de pieds / Acabados de pies

# Morfeo\_



patented model

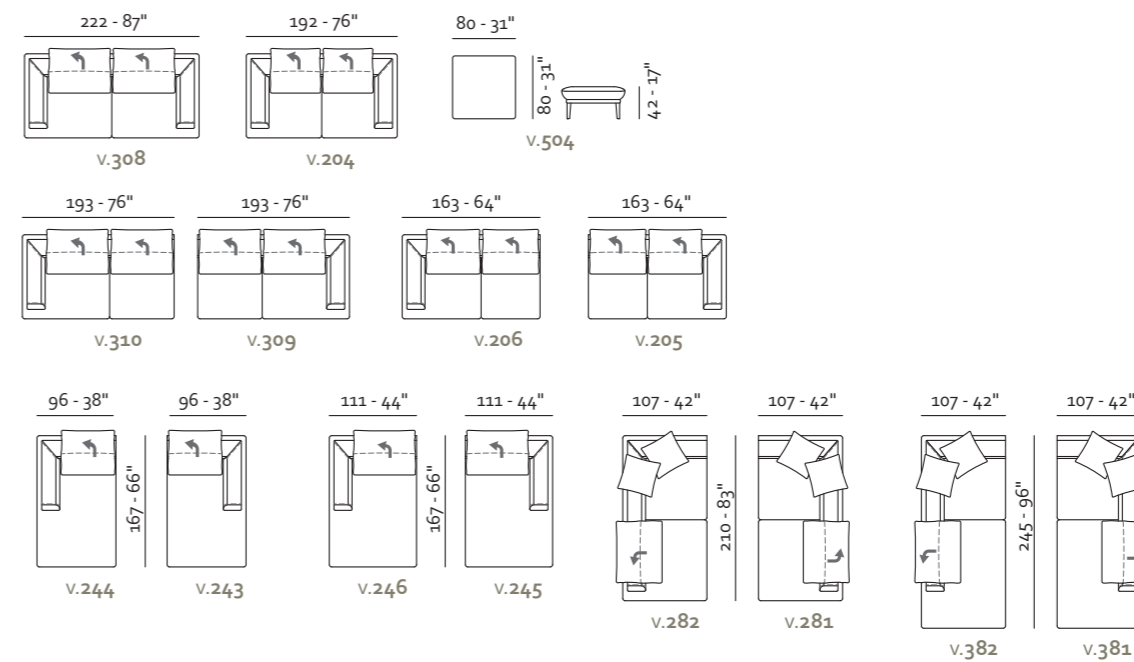
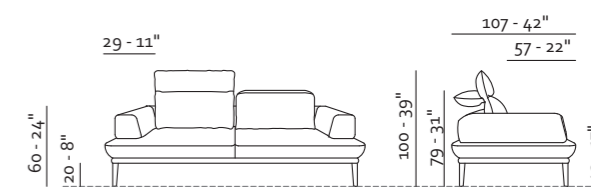

- **Rivestimento**  
Pelle / Tessuto
- **Imbottitura**  
BRACCIOLI / Poliuretano espanso  
SEDUTA / Poliuretano espanso  
SPALLIERA / Poliuretano espanso
- **Opzioni** Cucitura a contrasto
- **Comfort Standard**
- **Piedi Metallo**
- **Struttura** Telaio in ferro e legno

- **Coverings**  
Leather / Fabric
- **Filling**  
ARMS / Foam  
SEAT CUSHION / Foam  
BACK CUSHION / Foam
- **Options** Contrast stitching
- **Comfort Standard**
- **Legs Metal**
- **Structure** Iron and wooden frame

- **Revêtement**  
Cuir / Tissu
- **Rembourrage**  
ACCOUDOIRS / Mousse  
ASSISE / Mousse  
DOSSIER / Mousse
- **Options** Coutures contrastées
- **Confort Standard**
- **Pieds Metal**
- **Structure** Structure en bois et fer

- **Revestimiento**  
Piel / Tela
- **Imbottitura**  
APOYABRAZOS / Poliuretano expandido  
SENTADA / Poliuretano expandido  
RESPALDO / Poliuretano expandido
- **Opciones** Costura en contraste
- **Confort Estándar**
- **Pies Metal**
- **Struttura** Estructura en madera y hierro

- **Finitura piedi / Legs finishes**  
Finition de pieds / Acabados de pies

## Esempi di componibilità - Sectionals examples - Exemples de compositions - Ejemplos de modularidad

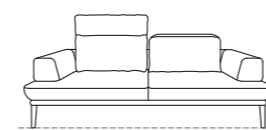
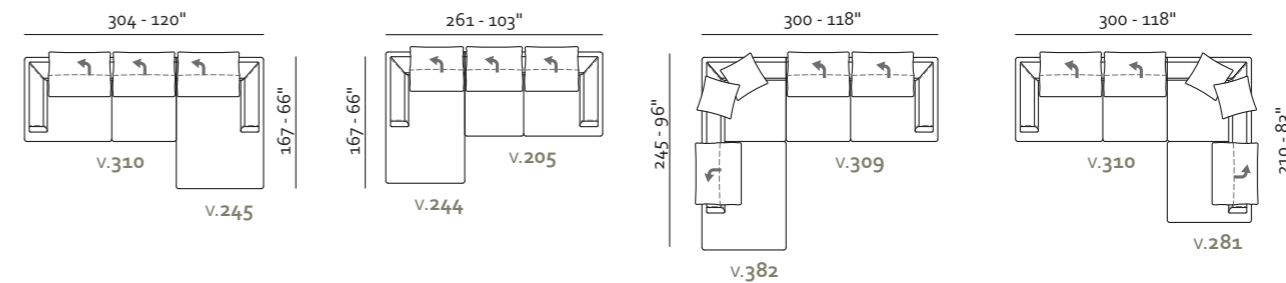

Rivestimento / Coverings  
Revêtement / Revestimiento

(A)

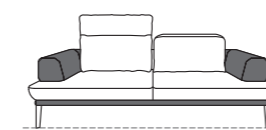

Rivestimento / Coverings  
Revêtement / Revestimiento

(B)

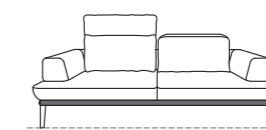

Rivestimento / Coverings  
Revêtement / Revestimiento

(C)

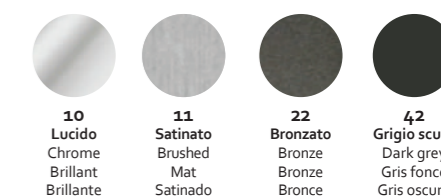
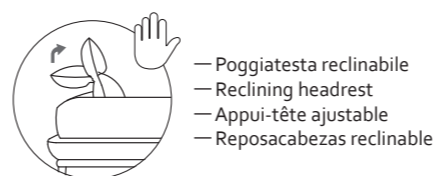

# Nuvola\_



patented model

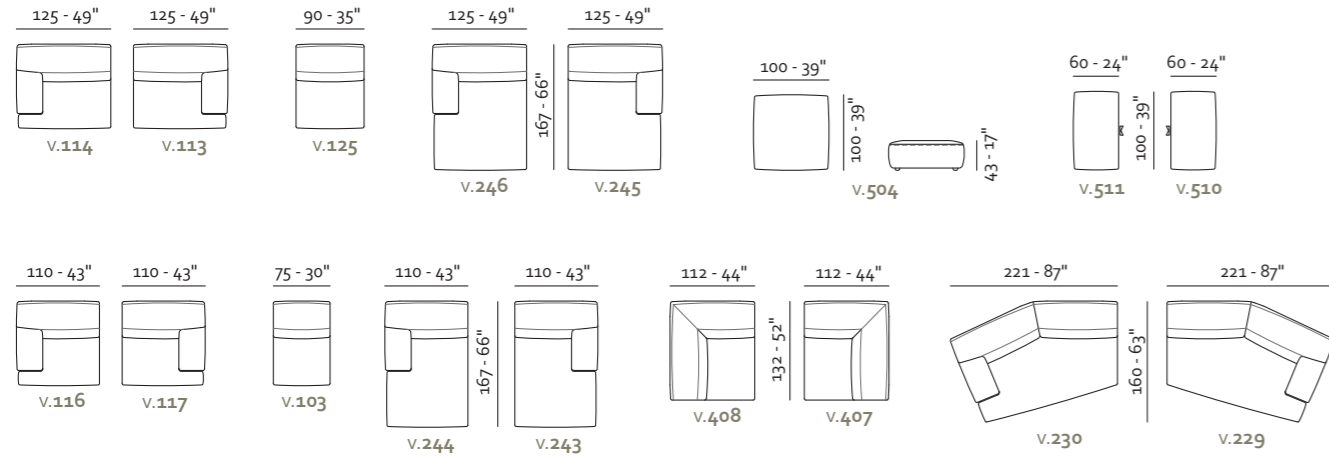
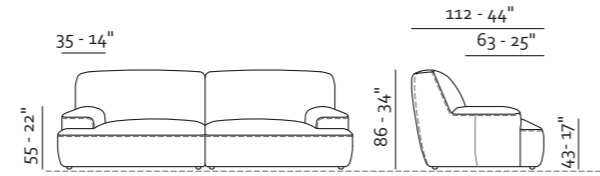

Esempi di componibilità - Sectionals examples - Exemples de compositions - Ejemplos de modularidad

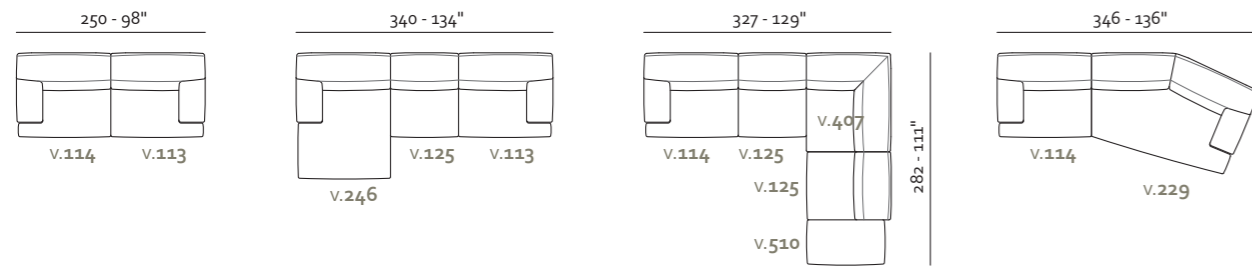

- Rivestimento  
Pelle / Tessuto
- Imbottitura  
BRACCIOLI / Poliuretano esp. + Microflock  
SEDUTA / Poliuretano esp. + Microflock  
SPALLIERA / Poliuretano esp. + Microflock
- Opzioni Cucitura a contrasto
- Comfort Standard
- Piedi Plastica
- Struttura Telaio in legno

- Coverings  
Leather / Fabric
- Filling  
ARMS / Foam + Microflock  
SEAT CUSHION / Foam + Microflock  
BACK CUSHION / Foam + Microflock
- Options Contrast stitching
- Comfort Standard
- Legs Plastic
- Structure Wooden frame

- Revêtement  
Cuir / Tissu
- Rembourrage  
ACCOUDOIRS / Mousse + Microflock  
ASSISE / Mousse + Microflock  
DOSSIER / Mousse + Microflock
- Options Coutures contrastées
- Comfort Standard
- Pieds Plastique
- Structure Structure en bois

- Revestimiento  
Piel / Tela
- Imbottitura  
APOYABRAZOS / Poliuretano expandido + Microflock  
SENTADA / Poliuretano expandido + Microflock  
RESPALDO / Poliuretano expandido + Microflock
- Opciones Costura en contraste
- Comfort Estándar
- Pies Plástico
- Estructura Estructura en madera

# Panuma\_

patented model

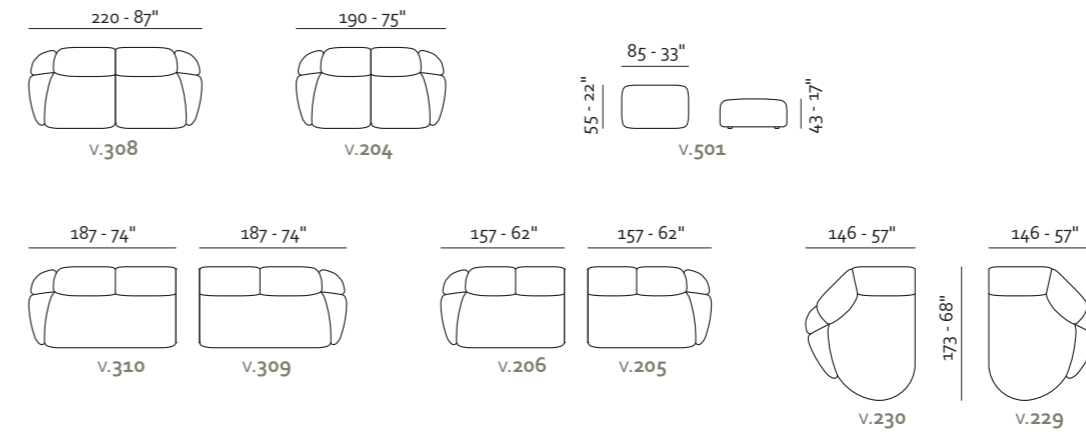
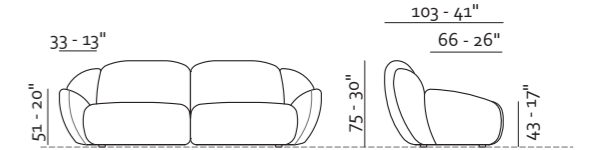

Esempi di componibilità - Sectionals examples - Exemples de compositions - Ejemplos de modularidad

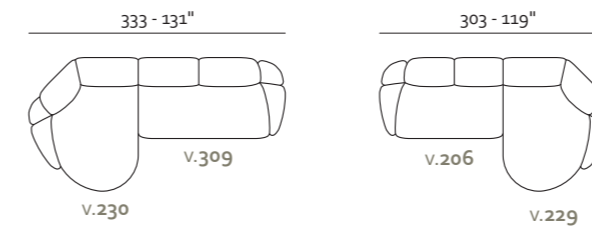

- Rivestimento  
Pelle / Tessuto
- Imbottitura  
BRACCIOLI / Poliuretano espanso  
SEDUTA / Poliuretano espanso  
SPALLIERA / Poliuretano espanso
- Opzioni Cucitura a contrasto
- Comfort Standard
- Piedi Plastica
- Struttura Telaio in legno

- Coverings  
Leather / Fabric
- Filling  
ARMS / Foam  
SEAT CUSHION / Foam  
BACK CUSHION / Foam
- Options Contrast stitching
- Comfort Standard
- Legs Plastic
- Structure Wooden frame

- Revêtement  
Cuir / Tissu
- Rembourrage  
ACCOUDOIRS / Mousse  
ASSISE / Mousse  
DOSSIER / Mousse
- Options Coutures contrastées
- Comfort Standard
- Pieds Plastique
- Structure Structure en bois

- Revestimiento  
Piel / Tela
- Imbottitura  
APOYABRAZOS / Poliuretano expandido  
SENTADA / Poliuretano expandido  
RESPALDO / Poliuretano expandido
- Opciones Costura en contraste
- Comfort Estándar
- Pies Plástico
- Estructura Estructura en madera

Percy\_

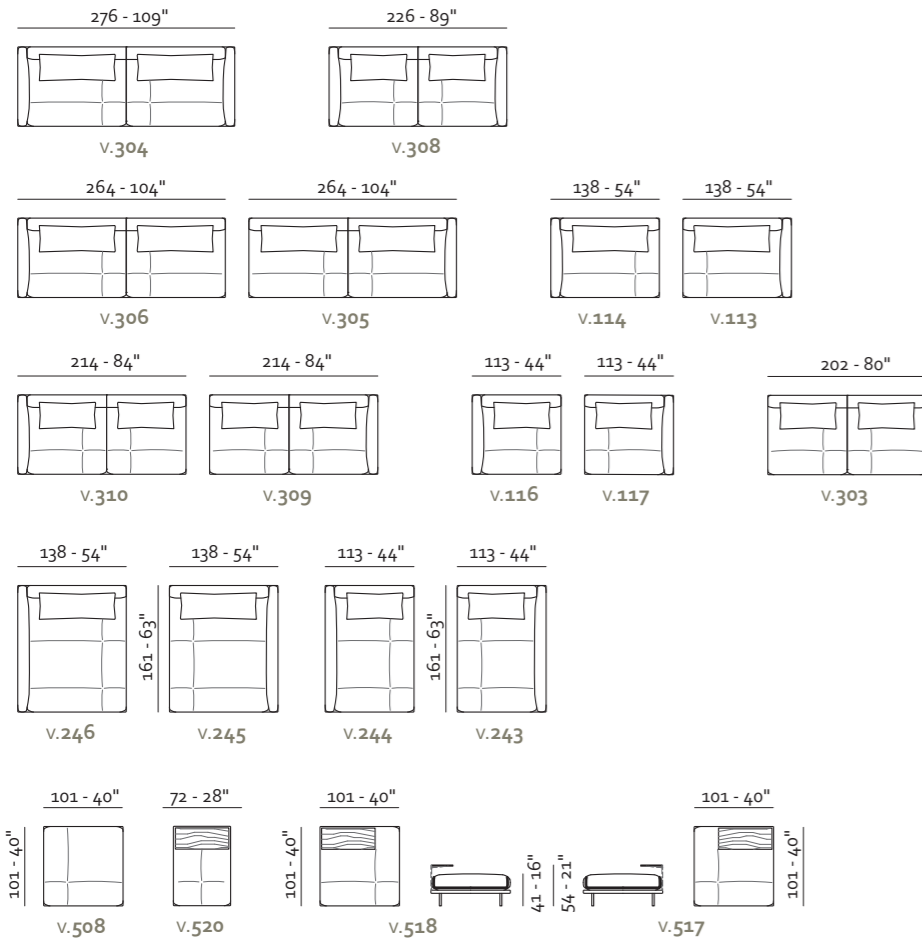

Esempi di componibilità - Sectionals examples - Exemples de compositions - Ejemplos de modularidad

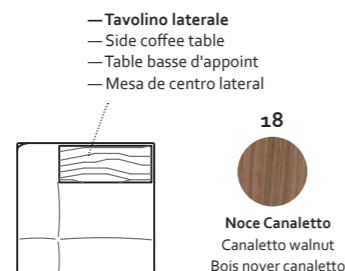
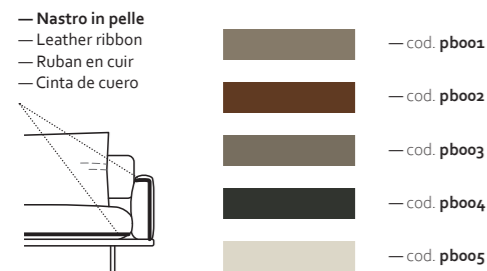
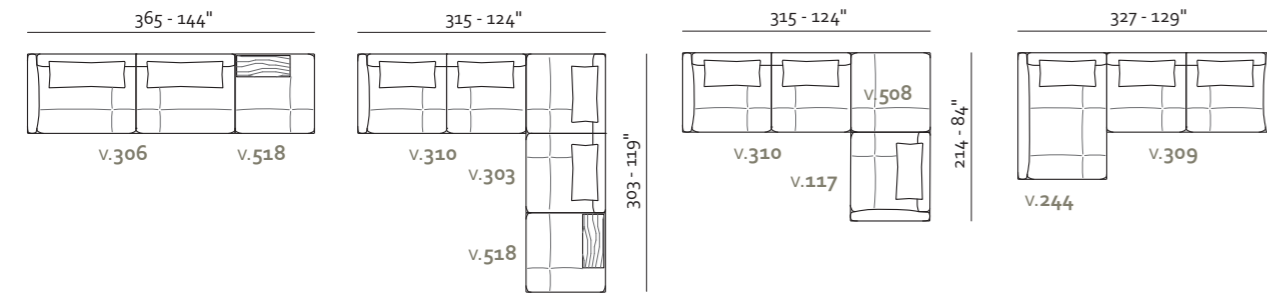

patented model

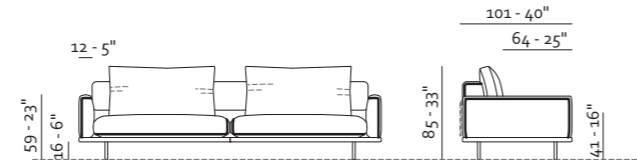

Sipario\_



patented model

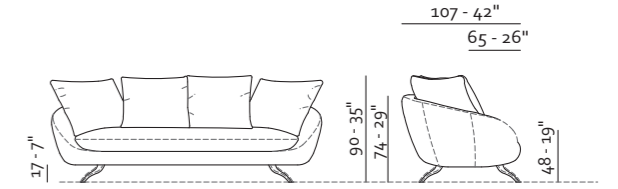

- Rivestimento  
Pelle / Tessuto
- Imbottitura  
BRACCIOLI / Poliuretano espanso  
SEDUTA / Poliuretano espanso-Memory  
SPALLIERA / Fibrapiuma - Poliuretano espanso
- Opzioni Cucitura a contrasto
- Comfort Standard
- Piedi Metallo
- Struttura Telaio in ferro e legno

- Coverings  
Leather / Fabric
- Filling  
ARMS / Foam  
SEAT CUSHION / Foam - Memory  
BACK CUSHION / Fiber - Foam
- Options Contrast stitching
- Comfort Standard
- Legs Metal
- Structure Iron and wooden frame

- Revêtement  
Cuir / Tissu
- Rembourrage  
ACCOUDOIRS / Mousse  
ASSISE / Mousse - Memory  
DOSSIER / Fiber -Mousse
- Options Coutures contrastées
- Confort Standard
- Pieds Metal
- Structure Structure en bois et fer

- Revestimiento  
Piel / Tela
- Imbottitura  
APOYABRAZOS / Poliuretano expandido  
SENTADA / Poliuretano expandido - Memory  
RESPALDO / Fiber - Poliuretano expandido
- Opciones Costura en contraste
- Confort Estándar
- Pies Metal
- Struttura Estructura en madera y hierro

- Finitura piedi e staffa spalliera  
— Legs finishing - back iron bracket  
— Finition des pieds - finition support dossier  
— Acabados de pies - seporte de hierro del respaldo

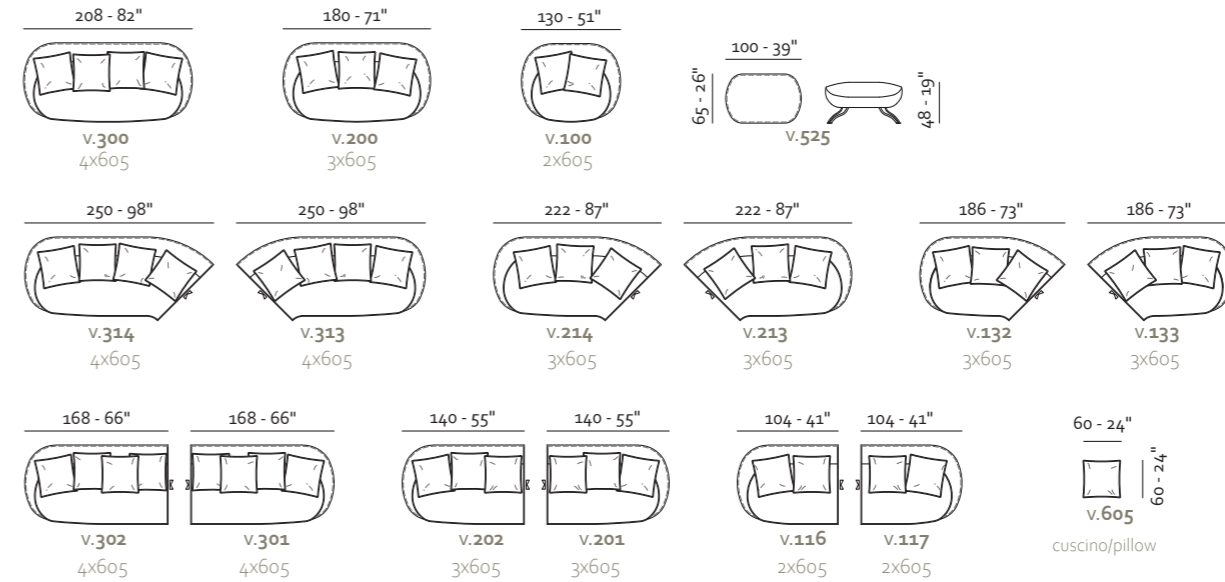

Esempi di componibilità - Sectionals examples - Exemples de compositions - Ejemplos de modularidad

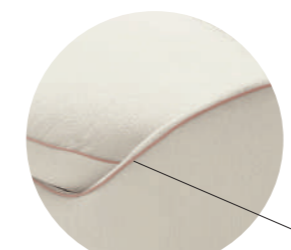
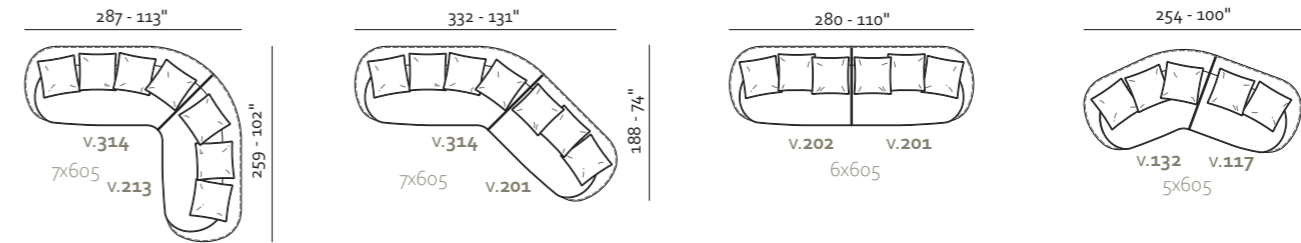

— Gros Grain

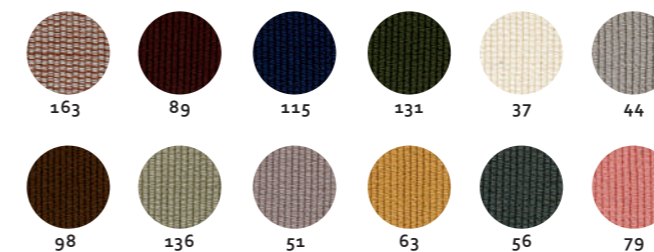

- Rivestimento  
Pelle / Tessuto
- Imbottitura  
BRACCIOLI / Poliuretano espanso  
SEDUTA / Poliuretano espanso - Piuma  
SPALLIERA / Piuma
- Opzioni Cucitura a contrasto
- Comfort Standard
- Piedi Metallo
- Struttura Telaio in legno

- Coverings  
Leather / Fabric
- Filling  
ARMS / Foam  
SEAT CUSHION / Foam - Feather  
BACK CUSHION / Feather
- Options Contrast stitching
- Comfort Standard
- Legs Metal
- Structure Wooden frame

- Revêtement  
Cuir / Tissu
- Rembourrage  
ACCOUDOIRS / Mousse  
ASSISE / Mousse - Plumes  
DOSSIER / Plumes
- Options Coutures contrastées
- Confort Standard
- Pieds Metal
- Structure Structure en bois

- Revestimiento  
Piel / Tela
- Imbottitura  
APOYABRAZOS / Poliuretano expandido  
SENTADA / Poliuretano expandido - Piuma  
RESPALDO / Piuma
- Opciones Costura en contraste
- Confort Estándar
- Pies Metal
- Struttura Estructura en madera

- Finitura piedi / Legs finishes  
Finition de pieds / Acabados de pies



# Sospiro\_

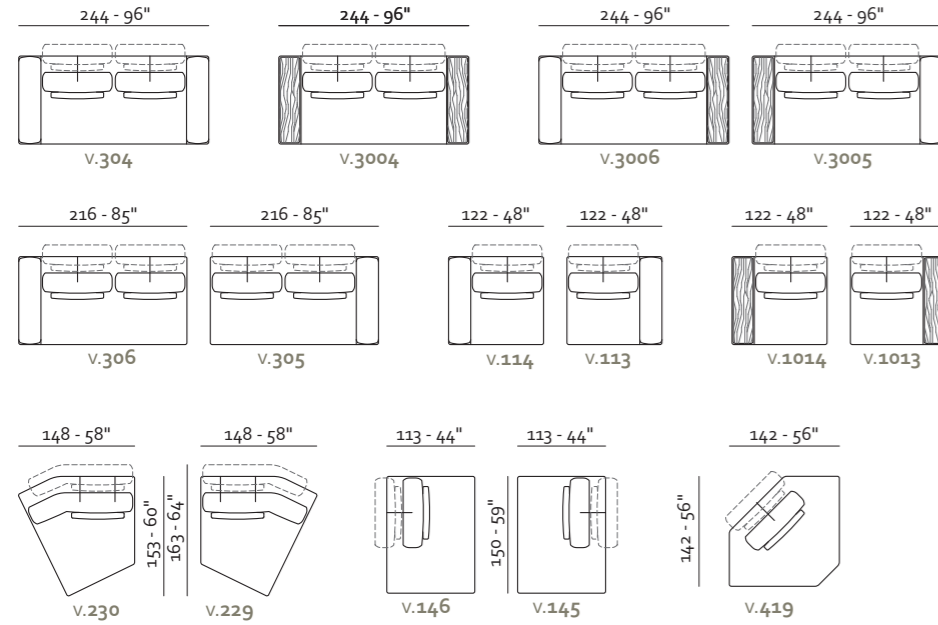

## Esempi di componibilità - Sectionals examples - Exemples de compositions - Ejemplos de modularidad

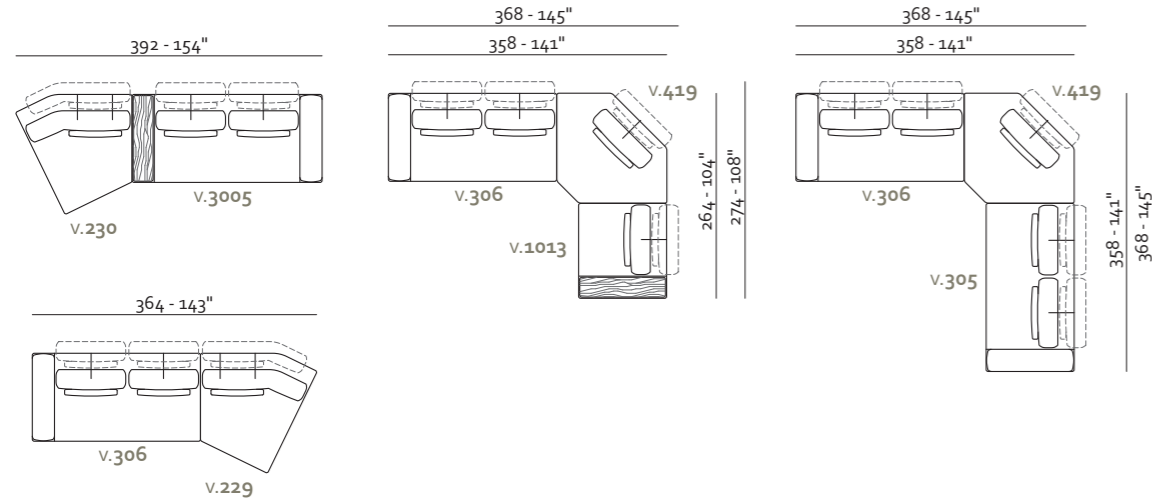

- Tavolino laterale
- Side coffee table
- Table basse d'appoint
- Mesa de centro lateral

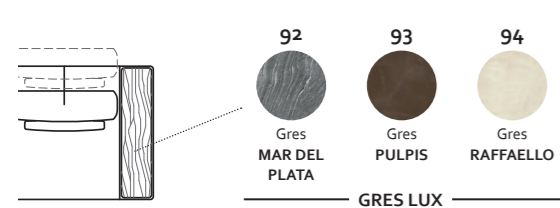

- Cucitura decorativa in tinta o a contrasto ed inserto in pelle
- Matching or contrast decorative stitching and leather insert
- Coutures décoratives assorties ou contrastées et empiècement en cuir
- Costuras decorativas a juego y en contraste, realizadas en piel/cuero

patented model

# Swing\_

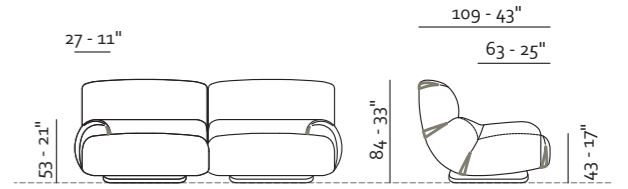

patented model

- Rivestimento
- Pelle / Tessuto
- Imbottitura
- BRACCIOLI / Poliuretano espanso
- SEDUTA / Poliuretano espanso 50Lynfa
- SPALLIERA / Poliuretano espanso - Piuma
- Opzioni Cucitura a contrasto
- Comfort Standard
- Piedi Metallo
- Struttura Telaio in legno

- Coverings
- Leather / Fabric
- Filling
- ARMS / Foam
- SEAT CUSHION / Foam 50Lynfa
- BACK CUSHION / Foam - Feather
- Options Contrast stitching
- Comfort Standard
- Legs Metal
- Structure Wooden frame

- Revêtement
- Cuir / Tissu
- Rembourrage
- ACCOUDOIRS / Mousse
- ASSISE / Mousse 50Lynfa
- DOSSIER / Mousse - Plumes
- Options Coutures contrastées
- Comfort Standard
- Pieds Metal
- Structure Structure en bois

- Revestimiento
- Piel / Tela
- Imbottitura
- APOYABRAZOS / Poliuretano expandido
- SENTADA / Poliuretano expandido 50Lynfa
- RESPALDO / Poliuretano expandido - Piuma
- Opciones Costura en contraste
- Comfort Estándar
- Pies Metal
- Struttura Estructura en madera

- Finitura piedi / Legs finishes
- Finition de pieds / Acabados de pies

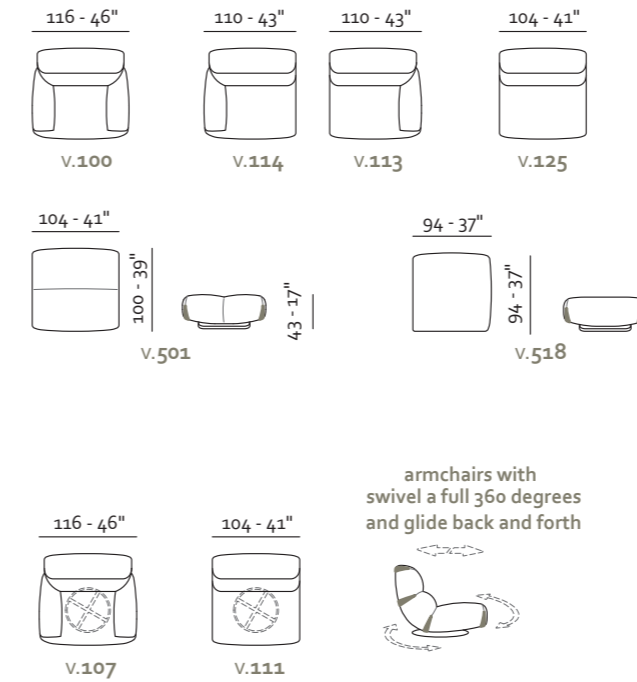
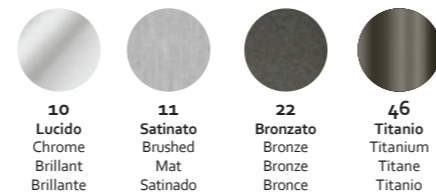

## Esempi di componibilità - Sectionals examples - Exemples de compositions - Ejemplos de modularidad

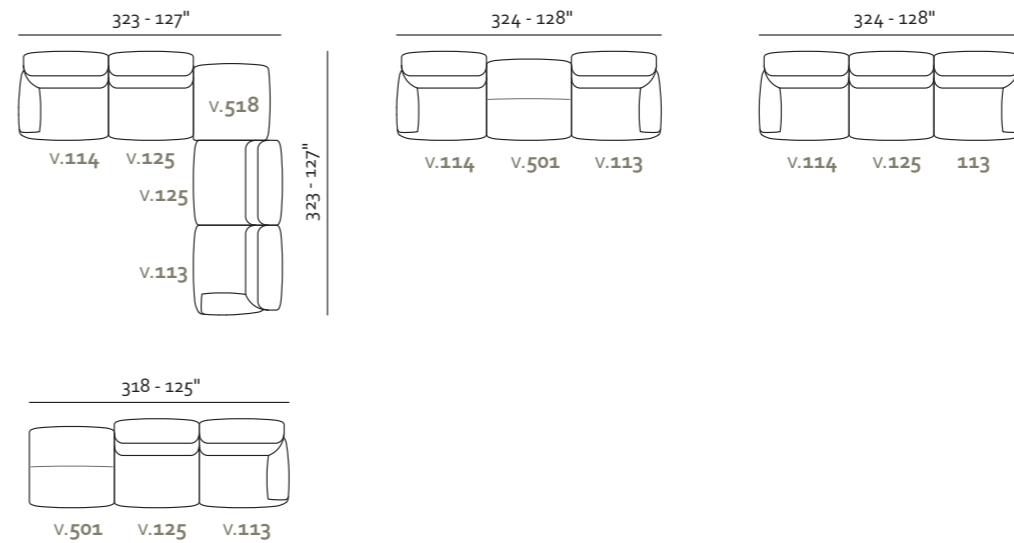

- Rivestimento
- Pelle / Tessuto
- Imbottitura
- BRACCIOLI / Poliuretano espanso
- SEDUTA / Poliuretano espanso
- SPALLIERA / Poliuretano espanso
- Opzioni Cucitura a contrasto
- Comfort Standard
- Piedi Metallo e legno
- Struttura Telaio in legno

- Coverings
- Leather / Fabric
- Filling
- ARMS / Foam
- SEAT CUSHION / Foam
- BACK CUSHION / Foam
- Options Contrast stitching
- Comfort Standard
- Legs Metal and wood
- Structure Wooden frame

- Revêtement
- Cuir / Tissu
- Rembourrage
- ACCOUDOIRS / Mousse
- ASSISE / Mousse
- DOSSIER / Mousse
- Options Coutures contrastées
- Comfort Standard
- Pieds Metal et bois
- Structure Structure en bois

- Revestimiento
- Piel / Tela
- Imbottitura
- APOYABRAZOS / Poliuretano expandido
- SENTADA / Poliuretano expandido
- RESPALDO / Poliuretano expandido
- Opciones Costura en contraste
- Comfort Estándar
- Pies Metal y madera
- Struttura Estructura en madera

## Abbracci\_

patented model

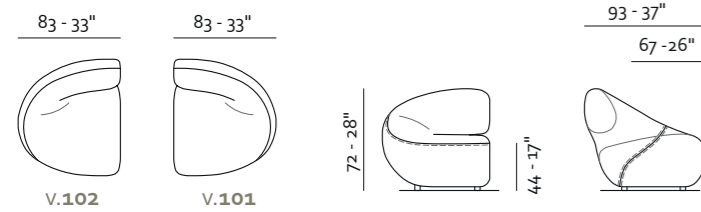

- **Rivestimento**  
Pelle / Tessuto
  - **Imbottitura**  
BRACCIOLI / Poliuretano espanso  
SEDUTA / Poliuretano espanso  
SPALLIERA / Poliuretano espanso
  - **Opzioni** Cucitura a contrasto
  - **Comfort** Standard
  - **Piedi** Plastica
  - **Struttura** Telaio in ferro
- **Coverings**  
Leather / Fabric
  - **Filling**  
ARMS / Foam  
SEAT CUSHION / Foam  
BACK CUSHION / Foam
  - **Options** Contrast stitching
  - **Comfort** Standard
  - **Legs** Plastic
  - **Structure** Iron frame
- **Revêtement**  
Cuir / Tissu
  - **Rembouillage**  
ACCOUDOIRS / Mousse  
ASSISE / Mousse  
DOSSIER / Mousse
  - **Options** Coutures contrastées
  - **Confort** Standard
  - **Pieds** Plastique
  - **Structure** Structure en fer

## Ember\_

patented model

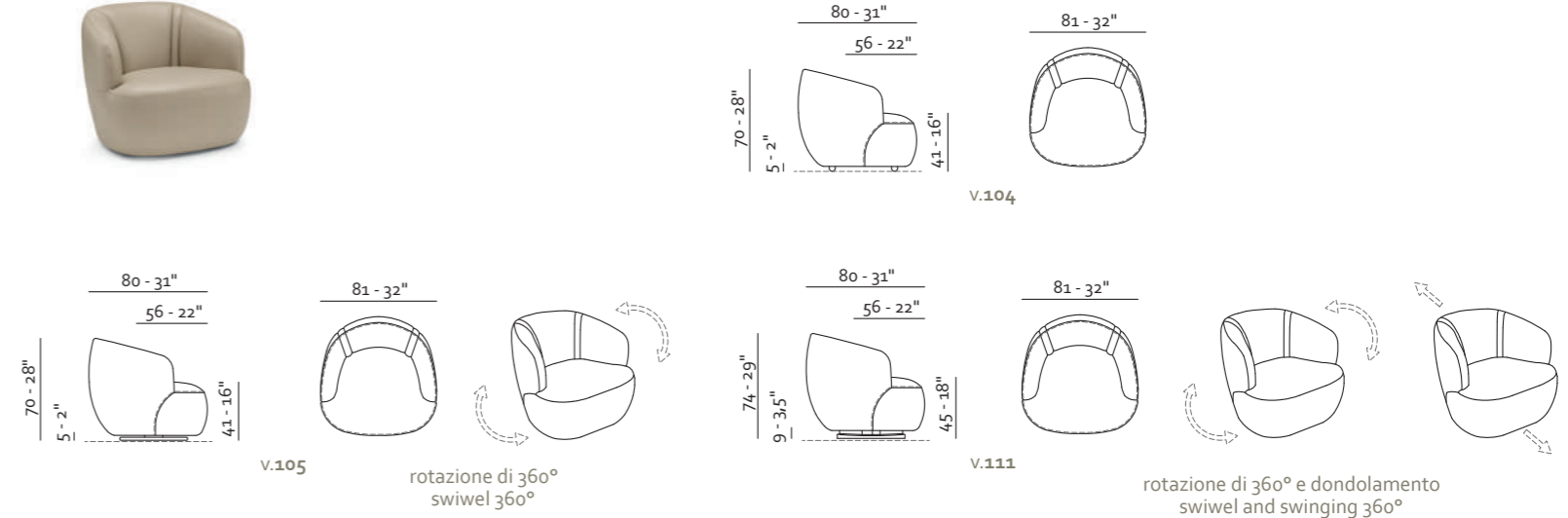

- **Rivestimento**  
Pelle / Tessuto
  - **Imbottitura**  
BRACCIOLI / Poliuretano espanso  
SEDUTA / Poliuretano espanso  
SPALLIERA / Poliuretano espanso
  - **Opzioni** Cucitura a contrasto
  - **Comfort** Standard
  - **Struttura** Telaio in legno
- **Coverings**  
Leather / Fabric
  - **Filling**  
ARMS / Foam  
SEAT CUSHION / Foam  
BACK CUSHION / Foam
  - **Options** Contrast stitching
  - **Comfort** Standard
  - **Structure** Wooden frame
- **Revêtement**  
Cuir / Tissu
  - **Rembouillage**  
ACCOUDOIRS / Mousse  
ASSISE / Mousse  
DOSSIER / Mousse
  - **Options** Coutures contrastées
  - **Confort** Standard
  - **Structure** Structure en bois
- **Revestimiento**  
Piel / Tela
  - **Imbottitura**  
APOYABRAZOS / Poliuretano expandido  
SENTADA / Poliuretano expandido  
RESPALDO / Poliuretano expandido
  - **Opciones** Costura en contraste
  - **Confort** Estándar
  - **Pies** Plástico
  - **Struttura** Estructura en madera

## Dana\_

patented model

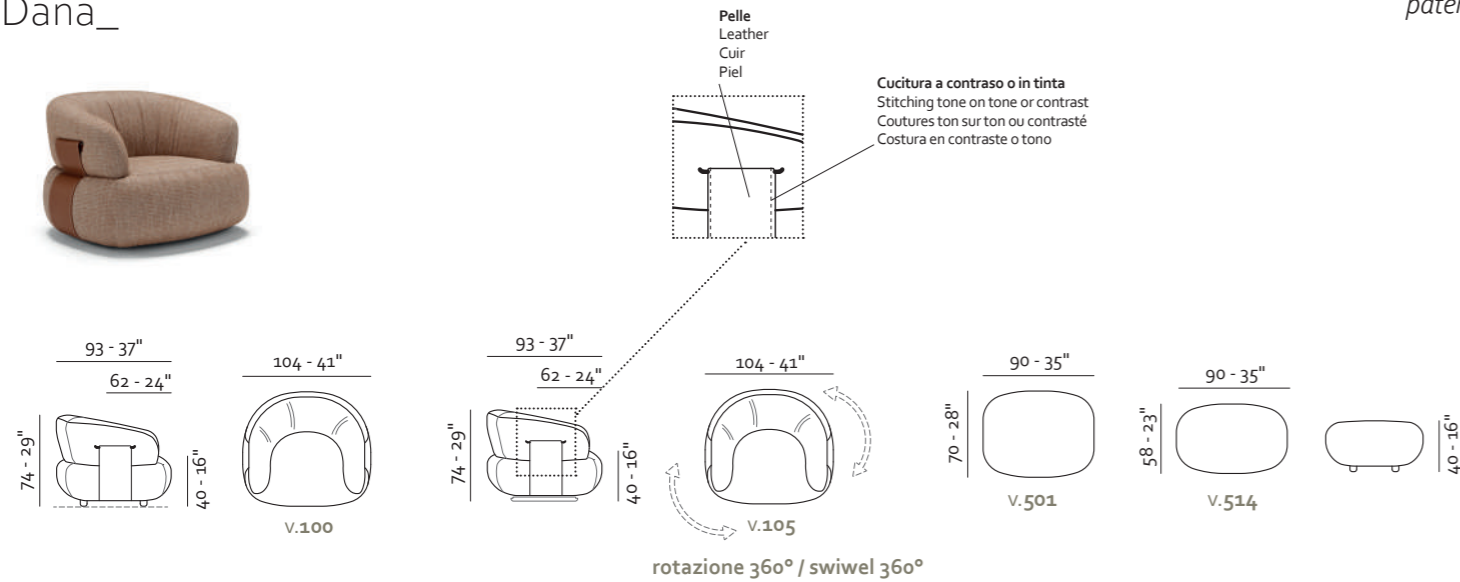

- **Rivestimento**  
Pelle / Tessuto
  - **Imbottitura**  
BRACCIOLI / Poliuretano espanso  
SEDUTA / Poliuretano espanso - 50 Lynfa  
SPALLIERA / Poliuretano espanso
  - **Opzioni** Cucitura a contrasto solo per la fascia in pelle
  - **Comfort** Standard
  - **Piedi** Plastica
  - **Struttura** Telaio in legno
- **Coverings**  
Leather / Fabric
  - **Filling**  
ARMS / Foam  
SEAT CUSHION / Foam - 50 Lynfa  
BACK CUSHION / Foam
  - **Options** Contrast stitching for leather detail only
  - **Comfort** Standard
  - **Legs** Plastic
  - **Structure** Wooden frame
- **Revêtement**  
Cuir / Tissu
  - **Rembouillage**  
ACCOUDOIRS / Mousse  
ASSISE / Mousse - 50 Lynfa  
DOSSIER / Mousse
  - **Options** Coutures contrastées bande accoudoir
  - **Confort** Standard
  - **Pieds** Plastique
  - **Structure** Structure en bois
- **Revestimiento**  
Piel / Tela
  - **Imbottitura**  
APOYABRAZOS / Poliuretano expandido  
SENTADA / Poliuretano expandido - 50 Lynfa  
RESPALDO / Poliuretano expandido
  - **Opciones** Costuras en contraste solo para detalles de cuero
  - **Confort** Estándar
  - **Pies** Plástico
  - **Struttura** Estructura en madera

## Muzzle\_

patented model



- **Rivestimento**  
Pelle / Tessuto
  - **Imbottitura**  
BRACCIOLI / Poliuretano espanso  
SEDUTA / Poliuretano espanso  
SPALLIERA / Poliuretano espanso
  - **Opzioni** Cucitura a contrasto
  - **Comfort** Standard
  - **Piedi** Metallo
  - **Struttura** Telaio in legno
- **Coverings**  
Leather / Fabric
  - **Filling**  
ARMS / Foam  
SEAT CUSHION / Foam  
BACK CUSHION / Foam
  - **Options** Contrast stitching
  - **Comfort** Standard
  - **Legs** Metal
  - **Structure** Wooden frame
- **Revêtement**  
Cuir / Tissu
  - **Rembouillage**  
ACCOUDOIRS / Mousse  
ASSISE / Mousse  
DOSSIER / Mousse
  - **Options** Coutures contrastées
  - **Confort** Standard
  - **Pieds** Metal
  - **Structure** Structure en bois
- **Revestimiento**  
Piel / Tela
  - **Imbottitura**  
APOYABRAZOS / Poliuretano expandido  
SENTADA / Poliuretano expandido  
RESPALDO / Poliuretano expandido
  - **Opciones** Costura en contraste
  - **Confort** Estándar
  - **Pies** Metal
  - **Struttura** Estructura en madera

## Perla\_

patented model

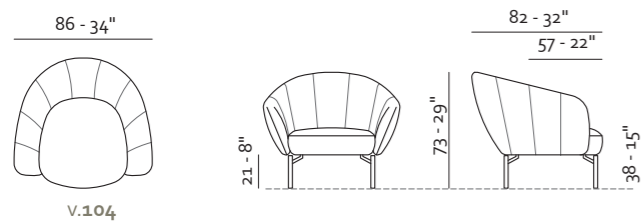

— Finitura piedi / Legs finishes  
Finition de pieds / Acabados de pies



- Rivestimento  
Pelle / Tessuto
- Imbottitura  
BRACCIOLI / Poliuretano espanso  
SEDUTA / Poliuretano espanso  
SPALLIERA / Poliuretano espanso
- Opzioni Bordino a contrasto
- Comfort Standard
- Piedi Metallo
- Struttura Telaio in legno

- Coverings  
Leather / Fabric
- Filling  
ARMS / Foam  
SEAT CUSHION / Foam  
BACK CUSHION / Foam
- Options Contrast piping
- Comfort Standard
- Legs Metal
- Structure Wooden frame

- Revêtement  
Cuir / Tissu
- Rembourrage  
ACCOUDOIRS / Mousse  
ASSISE / Mousse  
DOSSIER / Mousse
- Options Passepoil contrasté
- Comfort Standard
- Pieds Metal
- Structure Structure en bois

- Revestimiento  
Piel / Tela
- Imbottitura  
APOYABRAZOS / Poliuretano expandido  
SENTADA / Poliuretano expandido  
RESPALDO / Poliuretano expandido
- Opciones Ribete de contraste
- Comfort Estándar
- Pies Metal
- Struttura Estructura en madera

## Swing\_

patented model



armchairs with  
swivel a full 360 degrees  
and glide back and forth

- Rivestimento  
Pelle / Tessuto
- Imbottitura  
BRACCIOLI / Poliuretano espanso  
SEDUTA / Poliuretano espanso  
SPALLIERA / Poliuretano espanso
- Opzioni Cucitura a contrasto
- Comfort Standard
- Piedi Metallo
- Struttura Telaio in ferro

- Coverings  
Leather / Fabric
- Filling  
ARMS / Foam  
SEAT CUSHION / Foam  
BACK CUSHION / Foam
- Options Contrast stitching
- Comfort Standard
- Legs Metal
- Structure Iron frame

- Revêtement  
Cuir / Tissu
- Rembourrage  
ACCOUDOIRS / Mousse  
ASSISE / Mousse  
DOSSIER / Mousse
- Options Coutures contrastées
- Comfort Standard
- Pieds Metal
- Structure Structure en fer

- Revestimiento  
Piel / Tela
- Imbottitura  
APOYABRAZOS / Poliuretano expandido  
SENTADA / Poliuretano expandido  
RESPALDO / Poliuretano expandido
- Opciones Costura en contraste
- Comfort Estándar
- Pies Metal
- Struttura Estructura en hierro

## Scott\_

patented model

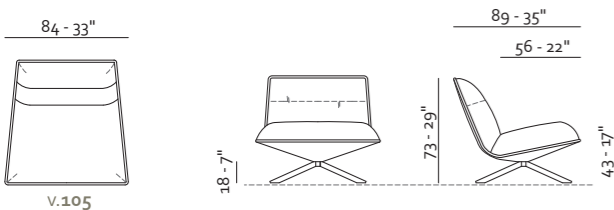

— Finitura piedi / Legs finishes  
Finition de pieds / Acabados de pies

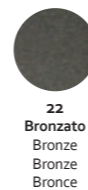

- Rivestimento  
Pelle / Tessuto
- Imbottitura  
SEDUTA / Poliuretano espanso  
SPALLIERA / Poliuretano espanso
- Opzioni Cucitura a contrasto
- Comfort Standard
- Piedi / Swivel Metallo
- Struttura Telaio in legno

- Coverings  
Leather / Fabric
- Filling  
SEAT CUSHION / Foam  
BACK CUSHION / Foam
- Options Contrast stitching
- Comfort Standard
- Legs / Swivel Metal
- Structure Wooden frame

- Revêtement  
Cuir / Tissu
- Rembourrage  
ASSISE / Mousse  
DOSSIER / Mousse
- Options Coutures contrastées
- Comfort Standard
- Pieds / Pivotant Metal
- Structure Structure en bois

- Revestimiento  
Piel / Tela
- Imbottitura  
SENTADA / Poliuretano expandido  
RESPALDO / Poliuretano expandido
- Opciones Costura en contraste
- Comfort Estándar
- Pies / Swivel Metal
- Struttura Estructura en madera

## Kea\_

patented model

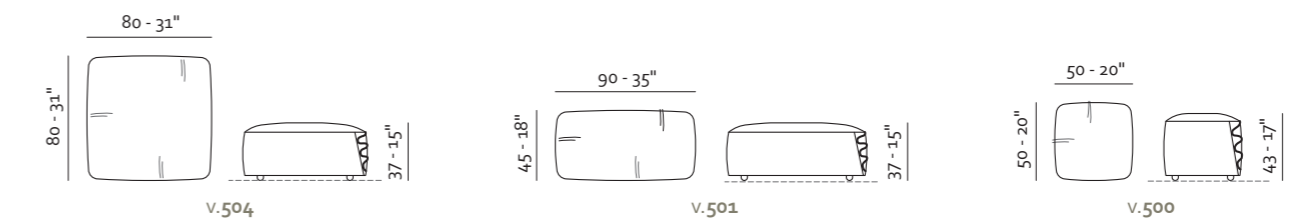
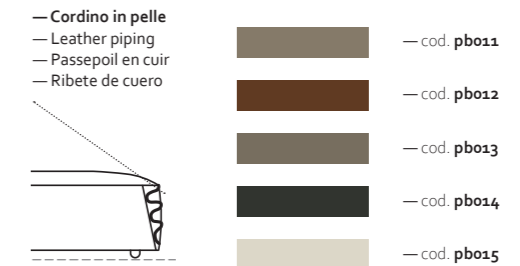

- Rivestimento  
Pelle / Tessuto
- Imbottitura  
SEDUTA / Poliuretano espanso
- Opzioni Cucitura a contrasto
- Comfort Standard
- Piedi Plastica
- Struttura Telaio in legno

- Coverings  
Leather / Fabric
- Filling  
SEAT CUSHION / Foam
- Options Contrast stitching
- Comfort Standard
- Legs Plastic
- Structure Wooden frame

- Revêtement  
Cuir / Tissu
- Rembourrage  
ASSISE / Mousse
- Options Coutures contrastées
- Comfort Standard
- Pieds Plastique
- Structure Structure en bois

- Revestimiento  
Piel / Tela
- Imbottitura  
SENTADA / Poliuretano expandido
- Opciones Costura en contraste
- Comfort Estándar
- Pies Plástico
- Struttura Estructura en madera

# Krisa\_

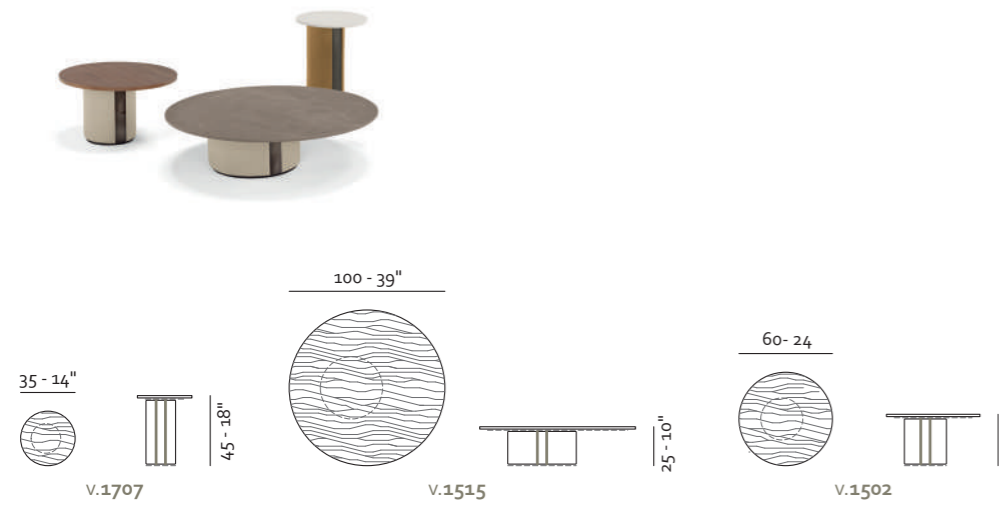

- Rivestimento  
Pelle / Tessuto
  - Opzioni Bordino a contrasto
  - Struttura Telaio in ferro e legno
- Revêtement  
Cuir / Tissu
  - Options Passepoil contrasté
  - Structure Structure en bois et fer
- Coverings  
Leather / Fabric
  - Options Contrast piping
  - Structure Iron and wooden frame
- Revestimiento  
Piel / Tela
  - Opciones Ribete de contraste
  - Struttura Estructura en madera y hierro

patented model



- Finitura piedi / Legs finishes  
Finition de pieds / Acabados de pies
- 22 Bronzato  
Bronze  
Bronze  
Bronce
- 46 Titanio  
Titanium  
Titane  
Titanio
- 18 Noce Canaletto  
Canaletto walnut  
Bois noyer canaletto  
Madera de nogal
- 92 Gres  
MAR DEL PLATA
- 93 Gres  
PULPIS
- 94 Gres  
RAFFAELLO
- GRES LUX

# Manfi\_

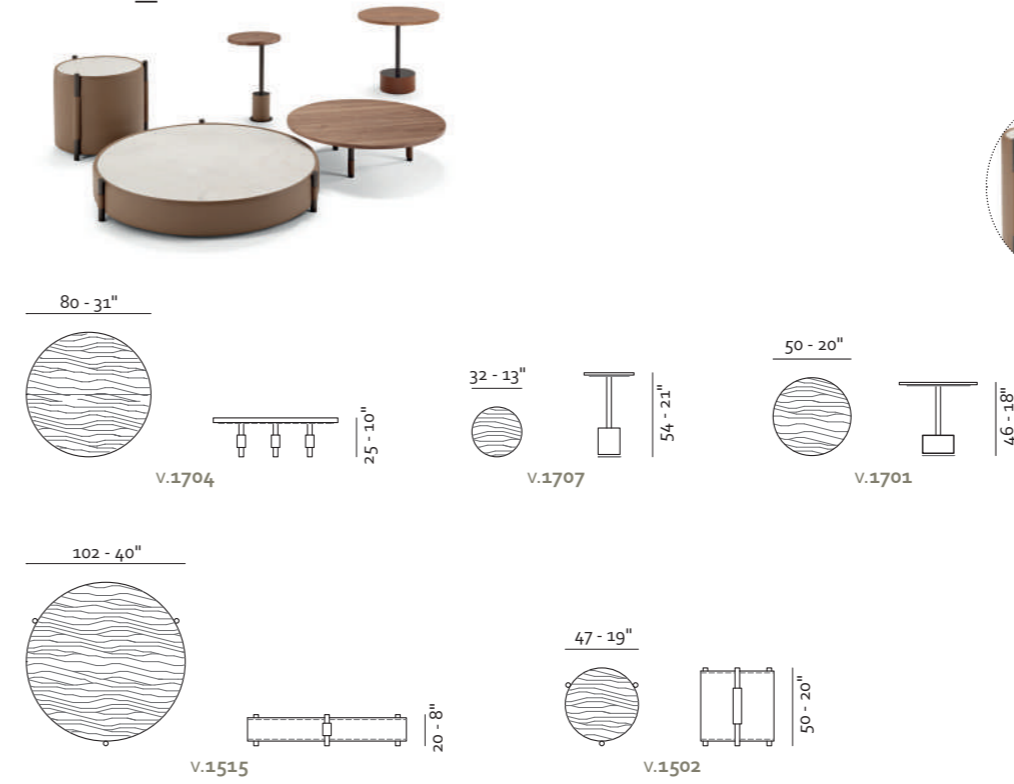

- Finitura ripiano / Table finishes  
Finition table / Acabados tablas
- 18 Noce Canaletto  
Canaletto walnut  
Bois noyer canaletto  
Madera de nogal
- 92 Gres  
MAR DEL PLATA
- 93 Gres  
PULPIS
- 94 Gres  
RAFFAELLO
- GRES LUX

patented model

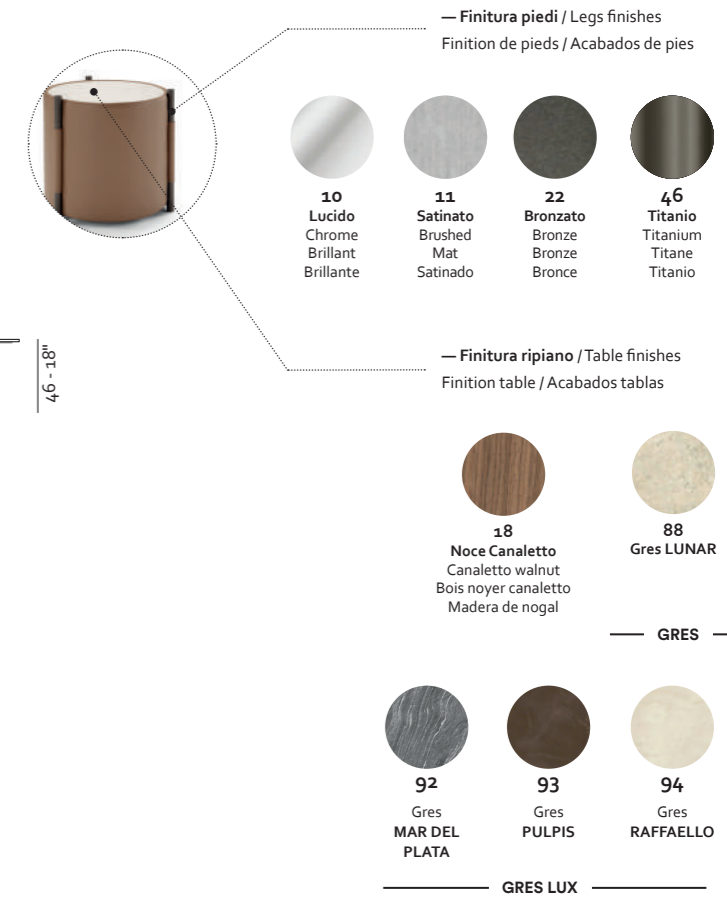

- Finitura piedi / Legs finishes  
Finition de pieds / Acabados de pies
- 10 Lucido  
Chrome  
Brillant  
Brillante
- 11 Satinato  
Brushed  
Mat  
Satinado
- 22 Bronzato  
Bronze  
Bronze  
Bronce
- 46 Titanio  
Titanium  
Titane  
Titanio
- 18 Noce Canaletto  
Canaletto walnut  
Bois noyer canaletto  
Madera de nogal
- 88 Gres LUNAR
- 92 Gres  
MAR DEL PLATA
- 93 Gres  
PULPIS
- 94 Gres  
RAFFAELLO
- GRES LUX

# Leia\_

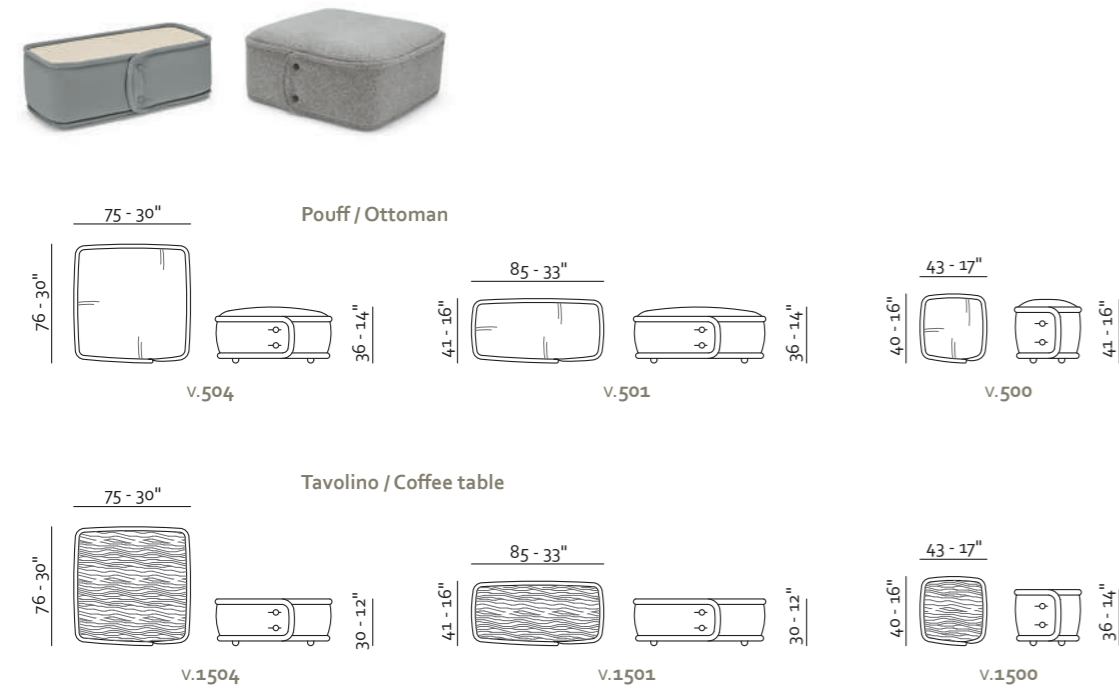

- Finitura ripiano / Table finishes  
Finition table / Acabados tablas
- 18 Noce Canaletto  
Canaletto walnut  
Bois noyer canaletto  
Madera de nogal
- 88 Gres LUNAR
- 92 Gres  
MAR DEL PLATA
- 93 Gres  
PULPIS
- 94 Gres  
RAFFAELLO
- GRES LUX

patented model

# Muzzle\_

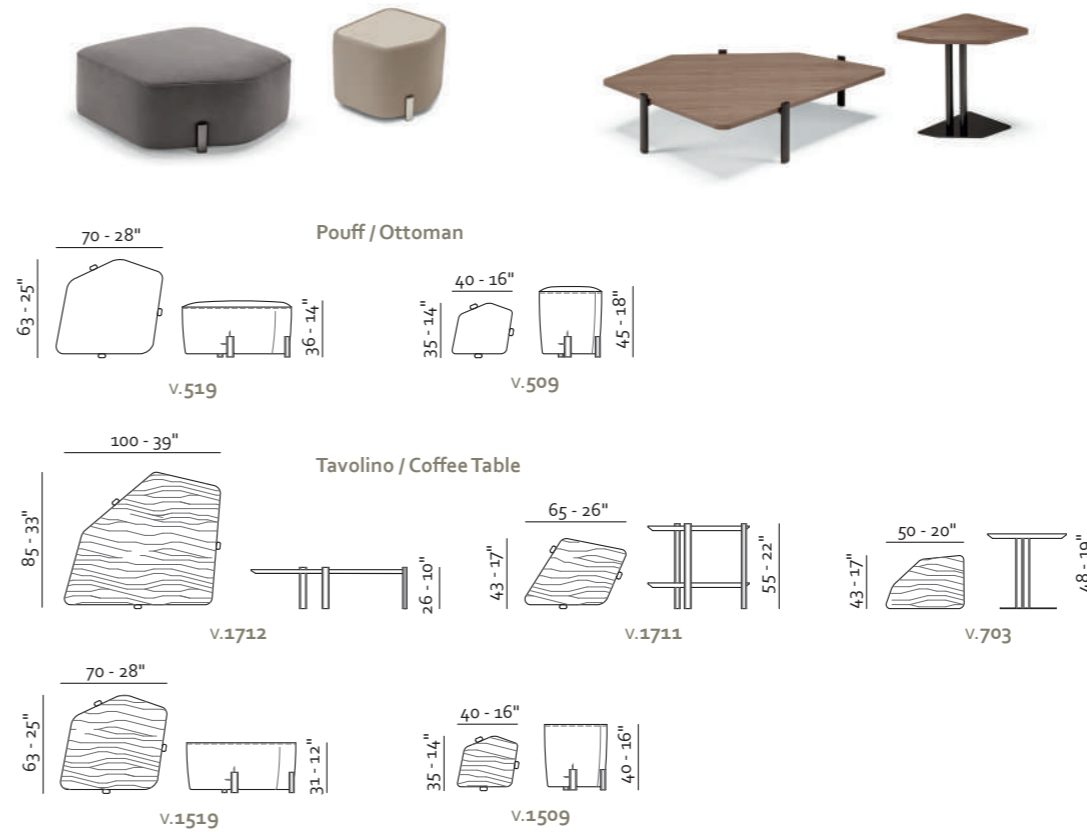

- Finitura ripiano / Table finishes  
Finition table / Acabados tablas
- 18 Noce Canaletto  
Canaletto walnut  
Bois noyer canaletto  
Madera de nogal
- 88 Gres LUNAR
- 92 Gres  
MAR DEL PLATA
- 93 Gres  
PULPIS
- 94 Gres  
RAFFAELLO
- GRES LUX

patented model



- Finitura piedi / Legs finishes  
Finition de pieds / Acabados de pies
- 10 Lucido  
Chrome  
Brillant  
Brillante
- 11 Satinato  
Brushed  
Mat  
Satinado
- 22 Bronzato  
Bronze  
Bronze  
Bronce
- 46 Titanio  
Titanium  
Titane  
Titanio
- 18 Noce Canaletto  
Canaletto walnut  
Bois noyer canaletto  
Madera de nogal
- 88 Gres LUNAR
- 92 Gres  
MAR DEL PLATA
- 93 Gres  
PULPIS
- 94 Gres  
RAFFAELLO
- GRES LUX

## Nel\_



Pouff / Ottoman

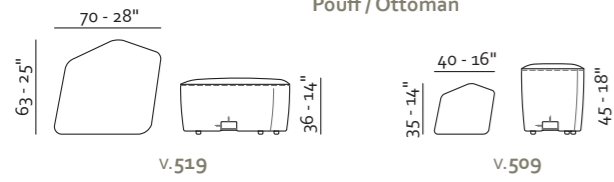

Tavolino / Coffee table

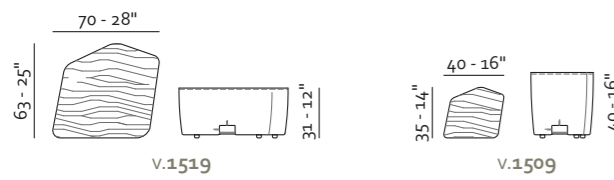

patented model

— Finitura piedi / Legs finishes  
Finition de pieds / Acabados de pies

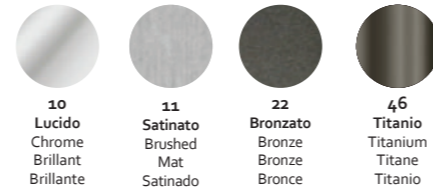

— Finitura ripiano / Table finishes  
Finition table / Acabados tablas



## Pocket\_cuscini - pillows

Rivestimento - Coverings - Revêtement - Revestimiento Pelle - Leather - Cuir - Piel / Tessuto - Fabric - Tissue - Tela



Pocket 01

Imbottitura - Filling - Rembourrage - Imbottitura  
Piuma - Feather - Plumes - Pluma

55x40 cm - 22"x16"



Pocket 02

Imbottitura - Filling - Rembourrage - Imbottitura  
Piuma - Feather - Plumes - Pluma

50x35 cm - 20"x14"



Pocket 03

Imbottitura - Filling - Rembourrage - Imbottitura  
Piuma - Feather - Plumes - Pluma

55x30 cm - 22"x12"



Pocket 04

Imbottitura - Filling - Rembourrage - Imbottitura  
Piuma - Feather - Plumes - Pluma

50x35 cm - 20"x14"



Pocket 05

Imbottitura - Filling - Rembourrage - Imbottitura  
Piuma - Feather - Plumes - Pluma

40x40 cm - 16"x16"



Pocket 06

Imbottitura - Filling - Rembourrage - Imbottitura  
Piuma - Feather - Plumes - Pluma

55x30 cm - 22"x12"

## Tarkin\_



Tavolino / Coffee table

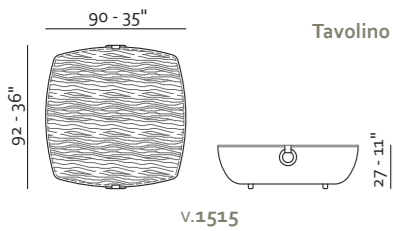

Pouff / Ottoman

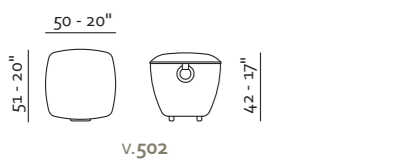
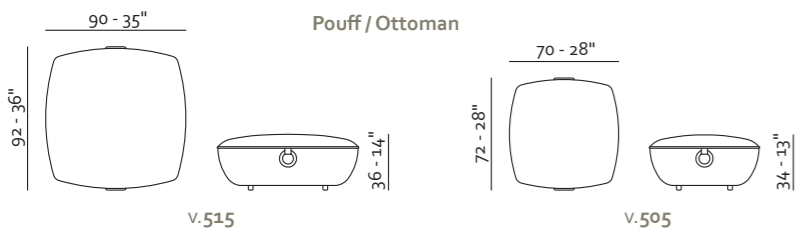

patented model

— Finitura piedi / Legs finishes  
Finition de pieds / Acabados de pies



— Finitura ripiano / Table finishes  
Finition table / Acabados tablas



## Cuscini - pillows

Rivestimento - Coverings - Revêtement - Revestimiento Pelle - Leather - Cuir - Piel / Tessuto - Fabric - Tissue - Tela



C1006

Imbottitura - Filling - Rembourrage - Imbottitura  
Fibra di poliestere - Fiber - Flocons de polyester - Fibras de poliéster

45x45 cm - 18"x18"



C1018

Imbottitura - Filling - Rembourrage - Imbottitura  
Piuma - Feather - Plumes - Pluma

45x45 cm - 18"x18"



C1023

Imbottitura - Filling - Rembourrage - Imbottitura  
Piuma - Feather - Plumes - Pluma

30x55 cm - 12"x22"



C1036

Imbottitura - Filling - Rembourrage - Imbottitura  
Poliuretano espanso - Foam - Mousse - Poliuretano expandido

60x60 cm - 24"x24"



C1039

Imbottitura - Filling - Rembourrage - Imbottitura  
Piuma - Feather - Plumes - Pluma

55x55 cm - 22"x22"

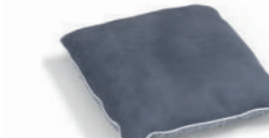

C1047

Imbottitura - Filling - Rembourrage - Imbottitura  
Piuma - Feather - Plumes - Pluma

Gross grain  
40x40 cm - 16"x16"



C1049

Imbottitura - Filling - Rembourrage - Imbottitura  
Piuma - Feather - Plumes - Pluma

40x50 cm - 16"x20"



C1051

Imbottitura - Filling - Rembourrage - Imbottitura  
Piuma - Feather - Plumes - Pluma

Nastro in pelle - Leather ribbon - Ruban en cuir - Cinta de cuero  
45x45 cm - 18"x18"

— Finitura piedi / Legs finishes / Finition de pieds / Acabados de pies

Metallo - Metal - Metal - Metal

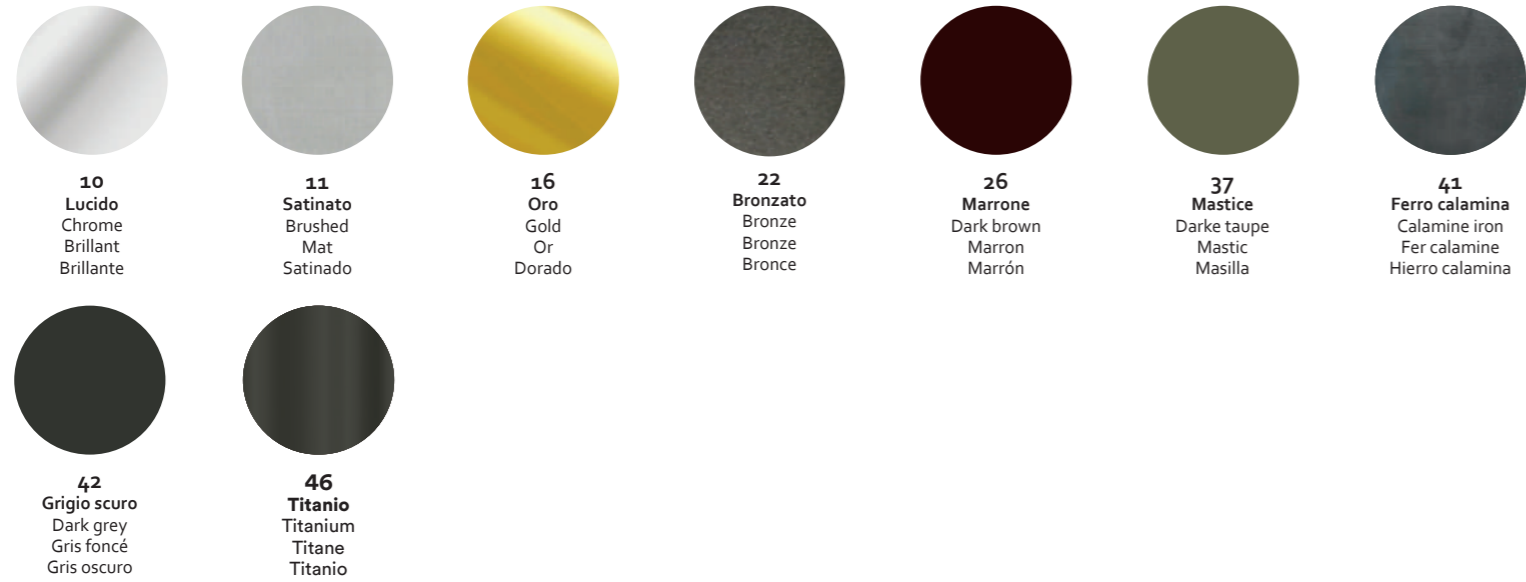

— Finitura ripiano / Tables finishes / Finition de table / Acabados tablas



LUX

— Finiture / Finishes / Finition / Acabados

Nastro in pelle - Leather ribbon - Ruban en cuir - Cinta de cuero  
mod. Percy\_



Cordino in pelle - Leather piping - Passepoil en cuir - Ribete de cuero  
mod. Kea\_

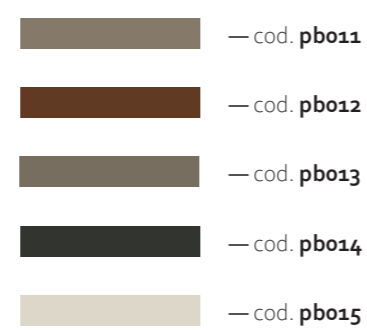

— I riferimenti dei colori qui riportati sono da considerarsi puramente indicativi. — Color reference shown is only indicative. — La référence coloris mentionnée est purement indicative. — Las referencias de color que se muestran aquí deben considerarse puramente indicativas.





**Maxdivani S.r.l.**  
Largo Epitaffio, 1  
70022 Altamura (Ba)  
Tel. +39 080 926 6200  
info@maxdivani.it  
maxdivani.it

Stampato in Italia - Ottobre 2024  
Printed in Italy - October 2024

La MAXDIVANI s.r.l. si riserva la facoltà di modificare in qualunque momento e senza preavviso, le caratteristiche tecniche degli elementi usati nel presente catalogo. Le misure riportate nei grafici possono subire variazioni dovute alla manifattura. Alcuni accessori presenti nelle immagini fotografiche non sono prodotti dalla MAXDIVANI s.r.l..  
Il presente catalogo è tutelato dalla legge sui diritti d'Autore (legge 22.4.1941, n° 633 e della legge 14.12.1942, n° 1485): e successive modifiche, di esso è proibita ogni riproduzione, totale o anche parziale in Italia o all'estero.

MAXDIVANI s.r.l. reserves the right to modify in any moment and without notice the technical characteristics of the elements used in this catalogue. Some dimensions reported in the schematics may be subject to modifications due to manufacturing. Some of the accessories shown in the pictures are not produced by MAXDIVANI s.r.l.. This catalogue is protected by the law on Author's Rights (law dated 22.04.1941, no. 633 and by the law dated 14.12.1942, no. 1485): and its following modifications. Any reproduction, complete or in part, is forbidden in Italy and abroad.

MAXDIVANI s.r.l. se réserve le droit de modifier à tout moment et sans préavis les caractéristiques techniques des éléments utilisés dans ce catalogue. Les mesures montrées dans les graphiques peuvent subir des variations dues à la fabrication. Certains accessoires présents dans les images photographiques ne sont pas produits par MAXDIVANI srl.  
Ce catalogue est protégé par la loi sur les droits d'auteur (loi 22.4.1941, loi n° 633 et loi 14.12.1942, n° 1485): telle que modifiée.  
Il est interdit toute reproduction, totale ou même partielle en Italie ou à l'étranger.

El MAXDIVANI s.r.l. se reserva el derecho de modificar en cualquier momento y sin previo aviso las características técnicas de los elementos utilizados en este catálogo. Las medidas que se muestran en los gráficos pueden sufrir variaciones debido a la fabricación. Algunos accesorios presentes en las imágenes fotográficas no son producidos por MAXDIVANI s.r.l.  
Este catálogo está protegido por la ley de derechos de autor (ley 22.4.1941, n° 633 y ley 14.12.1942, n° 1485) Está prohibido cualquier reproducción, total o parcial en Italia o en el extranjero.